

2025

PURDUE GRAND PRIX RULES





PREFACE

The rules apply to the Purdue Grand Prix Foundation's (PGPF) annual Purdue Grand Prix (PGP). Each member has been provided with or has been given access to the rules, is deemed to have full awareness and understanding of the rules and has agreed to abide by and be personally responsible for compliance with the rules.

Note: Any monetary fees, fines, etc. mentioned in the rules may be paid via cash or check to the Purdue Grand Prix Foundation through the Business Office for Student Organizations.

Further information may be obtained by contacting the Purdue Grand Prix Foundation offices at:

Purdue Union B050F
West Lafayette, IN 47907

Email- race@purduegrandprix.org



REVISIONS

PGPF reserves the right to amend and/or revise the rules at any time throughout an event (Rule 1.1.2.2.). All revisions and/or amendments to the rules shall be noted here with a date, Section number, Rule number, and brief summary of what is being revised and/or amended. Amended/revised rules are highlighted.



Contents

1. GENERAL	5
2. ENTRANTS/DRIVERS.....	12
3. ENTRIES.....	15
4. AT TRACK PROCEDURES	16
5. QUALIFICATIONS	23
6. PENALTIES	26
7. PROTESTS	28
8. APPEALS	29
9. TECHNICAL REQUIREMENTS	31
10. SAFETY EQUIPMENT	47
11. DRIVING PRACTICES.....	51
12. HAND SIGNALS.....	52
13. THE "HALLOWEEN HUNDRED" EXHIBITION RACE	53



1. GENERAL

1.1. GOVERNANCE

1.1.1. General

1.1.1.1. The Rules govern the Purdue Grand Prix and supersede all previous Rules, bulletins, and supplementary Rules and regulations, unless otherwise indicated.

1.1.1.2. Each Member is personally responsible for the Member's awareness, understanding, and compliance with the Rules.

1.1.1.2.1. A Member is defined as anyone serving on a team, a member of PGPF, the Safety Committee, Media, and officers contracted by PGPF.

1.1.1.3. PGPF may penalize any Member and/or exclude any Member or equipment from any Event if PGPF or representatives of the Safety Committee deems any act, any omission, any condition to be hazardous and/or not meeting the specifications, requirements, unsportsmanlike conduct, illustrations, and/or intent of, the Rules. Acts, omissions or conditions that may warrant penalty and/or exclusion include without limitation any action which PGPF deems to be a threat to or a violation of the integrity or safety of PGPF and/or the Event.

1.1.1.3.1. Unsportsmanlike conduct includes but is not limited to acts of aggression, profanity, or insults towards members of other teams or part of/invited by the foundation.

1.1.2. Purdue Grand Prix Authority

1.1.2.1. The Rules shall be applied, constructed, and interpreted by PGPF, and PGPF's application, construction, and interpretation shall be final and binding.

1.1.2.2. Any articles relating to kart specifications, participant qualifications, and safety are written and approved as an action of the Grand Prix Safety Committee. These rules are permanent and may be amended by the Grand Prix Safety Committee only. The Safety Committee reserves the right to revise these articles at any time, including, without limitation, prior to or during an Event. Notices, bulletins, supplementary Rules, regulations, and penalties are effective on the date and time issued, regardless of the date and time when a member receives actual notice.

1.1.2.3. Additional articles relating to procedures and additional information not related to 1.1.2 may be amended by simple majority vote of the Grand Prix Senior Board.

1.1.2.4. Any violations of the University Regulations will be subject to disciplinary procedures with the Office of the Dean of Students.



1.1.3. Officiating

1.1.3.1. PGPF will select Officials, including, but not limited to, Chief Starter, Technical Inspectors, Race Officials, etc.

1.1.3.2. The Grand Prix Safety Committee is composed of:

1.1.3.2.1. President of the Purdue Grand Prix Foundation.

1.1.3.2.2. Race Director(s) of the Purdue Grand Prix Foundation.

1.1.3.2.3. Technical inspectors acceptable to the Purdue Grand Prix Foundation and Purdue University.

1.1.3.2.4. Representative from Purdue's Student Activities and Organizations Department.

1.1.3.2.5. Representative from the Environmental Health and Public Safety Department.

1.1.3.3. PGPF shall have the authority to take any actions and make any determinations it deems necessary or appropriate during, or in connection with, an Event including without limitation determinations as to whether a Rule violation has occurred, whether a penalty should be imposed, the specifications of any penalty and the enforcement of any penalty.

1.1.3.4. In order to maintain transparency of all judgements and decisions made by PGPF, PGPF shall publicly publish a notice stating that PGPF has penalized a Member and/or rendered a judgement on a review and/or appeal. The notice may include without limitation a description of the penalty or judgement and names of the affected Member(s). Having accepted the privileges and obligations of membership, the Members referenced in any such notice waive any and all rights of action against PGPF and/or against any individual or entity publishing such notice. PGPF may without limitation publicize the results referenced in such notice in the positing and awards or otherwise.

1.1.3.5. PGPF will:

1.1.3.5.1. Secure necessary timing and scoring and technical equipment, excluding transponder. See Rule 4.2.1.3.

1.1.3.5.2. Record all timing and scoring information and technical information, including the standings of an Event.

1.1.3.5.3. Control the designated timing and scoring and technical areas.

1.1.3.5.4. Provide competition information to the Competitors and the press.

1.1.3.5.5. Facilitate the awards distributions.



1.1.3.6. PGPF shall be the final authority on the content of all official postings.

1.1.4. Acceptance of the Rules

1.1.4.1. Every Member who is involved in and/or participated in any way in any Event shall be deemed to have a full awareness and understanding of and to have accepted, the Rules.

1.1.4.2. Every Member agrees to follow the direction of PGPF and Safety Committee with respect to the enforcement and interpretation of these Rules or be subjected to penalties for failure to comply with such directions.

1.1.5. Assumption of Risk, Liability Release, Medical Insurance, Acknowledgement and Indemnity

1.1.5.1. ASSUMPTION OF RISK - EVERY MEMBER AGREES TO BE BOUND BY THE RULES AND ASSUMES ALL OF THE RISK OF SUCH MEMBER'S INVOLVEMENT AND/OR PARTICIPATION IN AN EVENT.

1.1.5.2. LIABILITY RELEASE - RECOGNIZING THAT KART RACING AND ALL OF THE ACTIVITY ASSOCIATED WITH IT ("ACTIVITY") CAN BE A HAZARDOUS UNDERTAKING, MEMBERS FOR THEMSELVES, THEIR HEIRS, EXECUTORS, REPRESENTATIVES, SUCCESSORS AND ASSIGNS, AGREE, BY THEIR MEMBERSHIP, THAT THEY RELEASE AND DISCHARGE PGPF, PURDUE UNIVERSITY, THE TRUSTEES OF PURDUE UNIVERSITY, AND ANY OF ITS OR THEIR DEPARTMENTS, TRUSTEES, AFFILIATED, EMPLOYEES, OFFICERS, AGENTS, AND INSURERS ("THE RELEASED PARTIES") FROM ANY AND ALL LIABILITY FOR DAMAGES TO PROPERTY, PERSONAL INJURY, AND/OR DEATH, IN ANY WAY RELATING TO ANY EVENT OR THE MEMBERS' INVOLVEMENT AND/OR PARTICIPATION IN THE ACTIVITY, REGARDLESS OF HOW THE INJURY OR EVENT MIGHT ARISE INCLUDING WITHOUT LIMITATION RACE OFFICATING, RULE INTERPRETATION AND VIOLATIONS, PHYSICAL CONDITION OF THE TRACK, AND/OR EMERGENCY TREATMENT OR RESCUE.

1.1.5.3. ACKNOWLEDGEMENT

1.1.5.3.1. MEMBERS RECOGNIZE THIS RELEASE APPLIES REGARDLESS OF WHETHER OR NOT INJURY OR EVENT MIGHT BE CAUSED IN WHOLE OR IN PART BY THE NEGLIGENCE OR OTHER FAULT OF THE RELEASED PARTIES. MEMBERS MAY BE ASKED TO ACKNOWLEDGE THIS ASSUMPTION OF RISK AND RELEASE BY OTHER AGREEMENTS THEY MIGHT SIGN AS A PREREQUISITE TO PARTICIPATE IN THE ACTIVITY.



1.1.5.4. **INDEMNITY** - EACH MEMBER ACKNOWLEDGES THAT MEMBER IS RESPONSIBLE FOR VIOLATION OF MEMBER'S AGREEMENTS BY MEMBER, MEMBERS'S REPRESENTATIVES INCLUDING LOVED ONES AFFECTED BY MEMBER'S INVOLVEMENT AND/OR PARTICIPATION, AND MEMBER'S PARTICIPANTS AND GUESTS. THIS RESPONSIBILITY APPLIES TO ALL VIOLATIONS OF MEMBER'S AGREEMENTS WITH PGPF. THIS INCLUDES THE MISUSE OF CREDENTIALS AND THE FAILURE TO ACCEPT THE ASSUMPTION OF RISK, THE WAIVER AND RELEASE OF LIABILITY, THE BINDING NATURE OF THE RULES, PGPF'S INTERPRETATION OF THE RULES, AND THE FINALITY OF THE APPEAL PROCEDURE. MEMBER UNDERSTANDS THAT THIS RESPONSIBILITY INCLUDES THE DUTY TO INDEMNIFY AND HOLD THE RELEASED PARTIES HARMLESS FROM AND AGAINST ANY AND ALL LOSSES, LIABILITIES, DAMAGES, COSTS OR EXPENSES (INCLUDING BUT NOT LIMITED TO REASONABLE ATTORNEYS' FEES AND OTHER LITIGATION COSTS AND EXPENSES) INCURRED BY ANY OF THE RELEASED PARTIES AS A RESULT OF ANY CLAIMS OR SUITS THAT I (OR ANYONE CLAIMING BY, UNDER OR THROUGH ME) MAY BRING AGAINST ANY OF THE RELEASED PARTIES TO RECOVER ANY LOSSES, LIABILITIES, COSTS, DAMAGES, OR EXPENSES THAT ARISE DURING OR RESULTING FROM MY PARTICIPATION IN THE ACTIVITY, REGARDLESS OF WHETHER OR NOT CAUSED IN WHOLE OR PART BY THE NEGLIGENCE OR OTHER FAULT OF ANY OF THE RELEASED PARTIES.

1.2. SAFETY

1.2.1. **Safety Policy** - While PGPF seeks to maintain safe conditions for Competitors and others taking into account all aspects of the Event, Members recognize that conditions may not be safe and can be affected by human error. At any Event, each Member acknowledges and agrees that racing is a hazardous activity and each Member's involvement and/or participation is with expressed assumption of this risk.

1.2.1.1. While acknowledging the inherent risk of racing to Competitors and other Members involved and/or participating in an Event, Members are personally responsible for their own safety, for the safety of each Member of Member Group and for the safety of their racing equipment.

1.2.1.2. PGPF may take any action including canceling, postponing, temporarily stopping or delaying an Event, if PGPF determines that basic safety requires such action. PGPF may order off the Track any Member or Kart that PGPF determines constitutes a hazard. PGPF may prohibit any Member or Member's equipment from entering or continuing in an Event.



1.2.2. Security

- 1.2.2.1. Only authorized individuals are permitted on the Track and in other restricted locations designated by PGPF.
- 1.2.2.2. Pit passes in the form of a picture I.D. badge will be issued to the Members upon passing technical inspection. All Members must have pit passes and their Purdue I.D. readily available to any Official via physical card or digital I.D.
- 1.2.2.3. Lost pit passes will require a \$15 replacement fee.
- 1.2.2.4. Misuse of I.D. badges by Members may lead to removal from the track and disqualification of the team from events at the discretion of the Race Director(s).
- 1.2.2.5. Misuse of I.D. badges by non-Members will lead to an automatic disqualification for that team for the year. Any badge being misused will be immediately destroyed.
- 1.2.2.6. If any person in the pits is not an official member of a crew and that crew is aware of their presence, that kart and crew will be disqualified from further participation in Events for that year. The Race Director(s), Pit Coordinator, and Safety Committee shall have complete discretion.
- 1.2.2.7. PGPF and any contracted service staff at the Track have the right to have the proper authority to engage in such searches of individuals as they deem necessary or appropriate for the safety and security of the Event. If they deem necessary, PGPF has the right but are not required to have the proper authority remove any individual and/or property from the Track.
- 1.2.2.8. The use of drones or any other unmanned aircraft systems (“UAS”) is prohibited unless approved in advance in writing by PGPF and is in compliance with the University policy as well as Federal and local policy and law. The use of drones must also be approved by PUPD and the airport.

1.2.3. Driver Self Extrication Requirement

- 1.2.3.1. Drivers are required to demonstrate the ability to exit the Kart within seven seconds to PGPF’s satisfaction by a method as determined by PGPF.

1.2.4. Data Sharing Policy - All Members agree:

- 1.2.4.1. PGPF owns any and all rights to exploit the Event including without limitation, all photographic, video, audio, films, still and/or motion picture images, sounds and data or other reproductions thereof.
- 1.2.4.2. PGPF may disclose the data to third parties for any purpose including, without limitation, safety and/or medical research.



1.3. ADVERTISING

1.3.1. PGPF may regulate or deny the advertising of any product on equipment, apparel or otherwise in connection with a Member or Event.

1.3.2. PGPF may disapprove advertising for any reason, including, without limitation, advertising which it determines offensive, inappropriate, illegal, undignified, in conflict with any PGPF sponsorship, in conflict with University regulations, potentially confusing or may detract from the interest in any Event and/or the integrity of PGPF and the University.

1.3.3. PGPF may require a Member to agree in writing with a policy statement regarding advertising of a particular product.

1.3.4. Advertising sponsors on the karts themselves shall be limited to signs located on front, rear, and side bumpers of the kart. The advertising in the front shall be at least 4 inches from each side of the front number panel.

1.3.5. An 18" x 36" professionally made sign may also be displayed on the half fence running along pit lane, determined by the Director of Marketing and Communications and/or Sales. A signed Supporter Agreement with PGPF along with a \$150 fee will be required to display the advertising. There will not be approvals granted on race day.

1.4. **ACTIVITIES** – PGPF may schedule mandatory meetings and/or activities for Members. PGPF may require a meeting with Member(s) at any time. Each Member must attend and actively participate in all official meetings and other activities designated by PGPF as mandatory for that Member at the times and locations designated by PGPF. These may include, but are not limited to the following:

1.4.1. **Competition**

1.4.1.1. **Competition Meetings** - PGPF may conduct one or more meetings of Drivers, Crew Chiefs, and Track Workers to discuss general application, construction and interpretation of the Rules.

1.4.1.2. **Driver Meetings** - Attendance at such Driver meetings may be limited to only the Driver participating in the Event. Additional attendees and alternate drivers may also be invited to attend.

1.4.1.3. **Track Worker Meetings** - In addition to attending any mandatory meetings, track workers may be required to demonstrate knowledge of the rules and on track procedures through such means including, but not limited to, quizzes and hands on knowledge tests.

1.4.2. **Media**



1.4.2.1. Pre-Race Activities

1.4.2.1.1. **Qualifications** - Drivers must attend the Pole winner photograph obligations.

1.4.2.1.2. **Pre-Race Ceremonies** - In preparation for the Race, Drivers shall follow the instructions of PGPF. Unless otherwise directed, the Drivers shall proceed to the Pre-Race stage and fully participate in Pre-Race ceremonies including without limitation any Driver introductions and/or Track laps.

1.4.2.2. **Post-Race Activities** - Upon completion of the Race, all Competitors shall follow the instructions of PGPF.

1.4.2.2.1. The winning Driver must attend and participate in post-Race interviews in victory lane. The winning Driver and Team agree to permit the display of the Kart in victory lane, as designated by PGPF, along with any sponsor(s) items as determined by PGPF. The winning Driver and Team agrees to participate in a photograph session with sponsor(s) and guests as determined by PGPF.

1.5. RACE DURATION

1.5.1. The scheduled number of laps for the main event is 160 laps.

1.5.2. The scheduled number of laps for the sprint races is 15 laps.



2. ENTRANTS/DRIVERS

2.1. ELIGIBILITY

- 2.1.1. A kart may be entered only by an officially recognized University organization, a group of students, or housing units in good standing with Purdue University.
- 2.1.2. All undergraduate crew members on a team shall be enrolled in Purdue University, or a Purdue affiliated university carrying a minimum of twelve credit hours offered by Purdue University.
- 2.1.3. All graduate crew members on a team shall be enrolled in Purdue University carrying a minimum of nine credit hours offered by Purdue University or a Purdue affiliated university.
- 2.1.4. Students in the cooperative education program are eligible to participate.
- 2.1.5. Crews must be composed of students attending the campus from which the kart is entered.
- 2.1.6. Any Driver wishing to compete in the main event must have participated in a minimum of four practice sessions. Participation counts as completing one full lap under the kart's own power recorded by the scoring system. The minimum number of practice sessions is subject to change at the Directors of Race discretion due to inclement weather or other uncontrollable factors.
- 2.1.7. No member of the Grand Prix Foundation Senior Board, Junior Board, Safety Committee, Grand Prix Queen Program, or scholarship applicant and/or recipient shall be permitted to be a member of any kart crew.
- 2.1.8. **Duration of Eligibility**
 - 2.1.8.1. Students may participate in the Grand Prix Race a maximum of five consecutive years from the first date of participation.
 - 2.1.8.2. Participation is defined as being a registered member of a crew as a driver, crew chief, or crew member at any time after the first practice has started.
- 2.1.9. A team will not be allowed to participate in an event if there are no eligible track workers available from the team.
- 2.1.10. Operating a combustion-driven race kart on the PGP track outside of PGPF-sanctioned events during the Spring semester will result in disqualification from the race unless approved by a race director.

2.2. CREW SIZE

- 2.2.1. The maximum number of members for a single team is seven.



2.2.2. Driver, crew chief, relief drivers, track workers, and any other general crew members are considered members of a team.

2.2.3. The minimum number of members for a single team is three. Including a driver, crew chief, and track worker.

2.2.4. No person may be a member of more than one crew.

2.3. CREW CHIEF

2.3.1. Each Entry must have a crew chief.

2.3.2. The crew chief is responsible for the kart complying with the Rules.

2.3.3. The crew chief shall serve as the official spokesperson of the crew's communication.

2.3.4. The crew chief must be in the kart's assigned Pit Box when the kart is on the Track and must accompany the kart during all technical inspection processes.

2.3.5. A crew chief cannot also be a relief driver.

2.3.6. No one other than the crew chief shall handle a situation with the Race Officials or the Race Director(s).

2.4. TRACK WORKER

2.4.1. Any team member expecting to function as a track worker must attend all required meetings for track workers. PGPF may also require additional training or meetings including, but not limited to, fire safety meetings, skills demonstrations, and knowledge quizzes.

2.4.2. Track workers are required to go straight out on the track as soon as the team has arrived inside the track or when instructed to by an official or Race Director.

2.4.3. Track workers are not allowed to leave the track until their entire team is packed and exiting the facilities.

2.4.4. Best practices for track workers can be found in supplemental publications from PGPF (See Appendix N).

2.4.5. Any crew member caught using an electronic device in the track may be immediately removed from the event and disqualified from future events. This may result in a Black Flag for their respective kart and disqualification for that day as well as the next running day. No warnings will be given for this offense and will result in a \$50 fine at the discretion of PGPF.

2.4.6. Track workers are required to wear a brightly colored safety vest with their team number clearly printed on the back. Safety vests may be rented from PGPF for a \$10 fee. This is a one-day rental; teams are required to have their own safety vest. Vests rented from the PGPF must be returned on the same day that they are rented.



2.5. RELIEF DRIVERS

- 2.5.1. A crew member may act as a relief driver if they meet all requirements of eligibility of a driver. Team size requirements must still be maintained.
- 2.5.2. Relief drivers must attend technical inspections and demonstrate fit and escape requirements same as primary driver.
- 2.5.3. The Crew Chief must inform a member of scoring when a driver change is made during practices.
- 2.5.4. If a relief driver is changed to be the primary driver, the Race Director(s) must be notified prior to the change occurring.

2.6. CREW CHANGES

- 2.6.1. Crew chief must send written notification to the Race Director(s) of any requested crew member changes after initial registration.
- 2.6.2. No changes may be made after the second technical inspection except in extreme cases as determined by the Race Director(s).

2.7. ROOKIE DRIVERS

- 2.7.1. Any driver or relief driver who has not participated in a previous Purdue Grand Prix main feature as a driver is considered a Rookie Driver. A Purdue Grand Prix main feature includes qualifications, sprint races, and the Purdue Grand Prix.
- 2.7.2. Before participating in any on track activities Rookie Drivers will be required to attend a rookie orientation program as determined by the Race Director(s). These may include, but are not limited to, on track rookie practice and driver orientations.
- 2.7.3. Failure to attend required events will prohibit the driver from participating in any on track activities. If a driver cannot attend these events, then they must notify the Race Director(s) prior to the scheduled events. It is at the discretion of the Race Director(s) to deem the reasoning as acceptable and take appropriate action.



3. ENTRIES

3.1. GENERAL

- 3.1.1. The form to complete registration can be found at purduegrandprix.org.
- 3.1.2. Registration opens December 1, 2024.
- 3.1.3. An application will not be complete until all required forms detailed in Section 3.2. and all fees detailed in Section 3.3 have been submitted.

3.2. REQUIRED FORMS

- 3.2.1. In addition to filling out the online entry form, each participant must sign the following forms and submit to the Purdue Grand Prix Foundation office, Purdue Union B050F.
 - 3.2.1.1. Waiver, Release, Hold Harmless, and Medical Insurance Form.
- 3.2.2. Forms may be found under the team information page on the Grand Prix website.

3.3. FEES

- 3.3.1. Registration fee for each kart is \$450, a \$50 discount will be applied if completed before the specified early registration time. No registrations will be accepted after the ending of the registration time.
 - 3.3.1.1. Registration discount ends on February 1st, 2025.
- 3.3.2. Registrations may be paid in cash, check, BOSO transfer, or online through TooCOOL.

3.4. DEADLINE

- 3.4.1. Unless otherwise specified, the deadline for all entries and team member changes is February 22, 2025, at 5 pm EST.
- 3.4.2. PGPF may refuse to accept late entries. Late entries, if accepted, may be penalized by PGPF.

3.5. REFUNDS

- 3.5.1. No refunds of any kind shall be given, except in the case of the cancellation of the race and the race is not rescheduled. In the event of cancellation with no reschedule, team's paid registration fee may be rolled over to the next year.



4. AT TRACK PROCEDURES

4.1. ON TRACK CONDITIONS AND FLAGGING USES

4.1.1. **Green Condition** - The Green Condition signifies racing conditions are clear to start.

4.1.1.1. **Practice** - A practice session has begun.

4.1.1.2. **Qualifications** - Qualification heat has begun.

4.1.1.3. **Race** - Unless otherwise instructed, a Race has begun.

4.1.2. **Yellow Condition** - The Yellow Condition signifies caution. This could indicate a partial blockage of the track or other unique circumstance that drivers should be on the lookout for.

4.1.2.1. Overtaking is not permitted between the first Yellow Condition and the subsequent Green Condition.

4.1.2.2. Drivers shall reduce speed immediately, proceed with caution, maintain position, and yield to safety personnel.

4.1.2.3. **Local Yellow**

4.1.2.3.1. At the display of a local yellow a driver must slow down, raise one hand, hold their position, and be prepared to stop.

4.1.2.3.2. Drivers must remain at a controllable speed until the first flag station that is not displaying a yellow flag. A controllable speed allows for rapid control of the kart.

4.1.2.4. **Full Course Yellow**

4.1.2.4.1. During a full course yellow, a driver must slow down, raise one hand to signal to the bridge, hold their position, and be prepared to stop.

4.1.2.4.2. Drivers must remain at a controllable speed until the track has entered the green condition or the full course yellow has been reduced to a local yellow. A controllable speed allows for rapid control of the kart.

4.1.2.5. A kart may pass another kart only if:

4.1.2.5.1. Both karts are in pit lane boundaries.

4.1.2.5.2. The other kart is stopped on the track.

4.1.2.5.3. PGPF or starter indicates to pass a kart.

4.1.2.6. A kart must not use pit lane to improve its position relative to any kart remaining on the racing surface, but a kart may improve its position relative to other karts in pit lane.

4.1.2.7. PGPF may impose black flag penalties for violation of any rules outlined above in Section 4.1.2. Yellow Condition.

4.1.2.8. PGPF has the right to assess a time penalty to remain in the pits.

4.1.3. **Red Condition** - The red condition signifies the suspension of on-track activities.



- 4.1.3.1. A red flag given to the entire field means that the track is hazardous for racing or the safety of personnel at the track is at risk due to karts operating on the track. All karts must pull off into the infield as safely and quickly as possible and kill the engine.
- 4.1.3.1.1. A red flag shall be thrown in the event of a kart tipping on its side or top, and the driver of the kart is required to be evaluated by medical personnel. The driver will only be able to return to racing after being cleared by the medical personnel.
- 4.1.3.1.2. In the event medical personnel are called to tend to a crew member, the red condition will be enforced from the time of calling until the medical personnel are cleared from inside the gate of the track.
- 4.1.3.1.3. The Foundation or Safety Officials may require a driver to be evaluated by medical personnel after an accident that may not include a kart tipping on its side or top.
- 4.1.3.2. No work may be performed on any kart whether on the track or in the pit lane while under the Red Condition during a main feature event.
- 4.1.3.3. As soon as instructed by the Race Director or Pit Coordinator, two crew members are allowed to attend to the kart and driver. They must bring only their kart stand, fire extinguisher, and starter motor.
- 4.1.3.4. If the race is to be restarted, the Race Director and Scoring and Timing Officials will position karts at the start/finish line in order of the last complete lap.
- 4.1.3.5. Unless otherwise declared by PGPF, a Race stopped by the declaration of a Red Condition due to inclement weather will be considered incomplete unless more than 50% of the scheduled number of laps has been completed by the race leader.
- 4.1.3.6. If a Red Condition is declared due to inclement weather and more than 25% and less than 50% of the schedule number of laps has been completed by the race leader the race will be restarted at a later time or on the scheduled rain date by lining up the karts in single file in the order of the last completed lap. If a Red Condition is declared due to inclement weather and less than 25% of the scheduled number of laps has been completed by the race leader the race will be restarted according to the race starting order.
- 4.1.4. The decision as to whether to declare a Green, Yellow, or Red Condition may not be reviewed and/or appealed.
- 4.1.5. **Black** - The driver shall proceed to his/her Pit Box on the next lap and follow the instructions of a race official.



4.1.6. **Rolled Black** - The rolled black flag will be given to any competitor whose driving conduct is bordering on penalization. This is only a warning and does not require the kart to leave the track.

4.1.7. **Blue** - The blue flag with or without the diagonal yellow stripe will be given to any kart which does not yield to an overtaking kart. The flagged kart must, within one lap, hold their line and signal the faster kart to pass. The flagged kart must indicate which side to pass on.

4.1.8. **White**

4.1.8.1. **Practice** - Indicates 5 minutes remaining in practice.

4.1.8.2. **Qualifications** - Indicates 1 minute remaining in heat.

4.1.8.3. **Race** - The leader has commenced his/her last lap and will continue to be displayed to all successive karts as they cross the start/finish line.

4.1.9. **Checkered** - The practice session, qualifying session, or race is completed. The winner should proceed on his/her parade lap while all other drivers must enter pit lane. The top five karts may stay in the infield for post-race ceremonies.

4.2. **TIMING AND SCORING**

4.2.1. **Systems**

4.2.1.1. The electronic system is the primary record.

4.2.1.2. PGPF may also consult with other Officials, review camera footage, and consider such other data as necessary or appropriate to decide the order of the karts.

4.2.1.3. All karts must be equipped with a scoring transponder provided by the team.

Required equipment includes: MyLaps transponder (either X2 or TR2) with an active subscription and mounting bracket.

4.2.1.4. Maintenance of the transponder is the responsibility of the furnishing team.

4.2.1.5. Transponders may be borrowed from the Grand Prix Foundation for one event at a time on a first come, first serve basis. If a borrowed transponder is not returned by the end of the event, a \$50 late return fee will be charged to the team. If a borrowed transponder is not returned by the end of the race, the team will be charged an additional replacement fee at the cost of a new transponder.

4.2.2. **Start/Finish Line** - The scoring of karts shall begin at the moment when:

4.2.2.1. **Race** - the timing transponder of the lead kart reaches the starting line after the prescribed number of parade and pace laps have been completed and the green flag has been displayed by the starter.



4.2.2.2. **Practice/Qualifications** - the declaration of the Green or Yellow Condition has been given by PGPF.

4.2.3. **Lap Credit**

4.2.3.1. A kart is credited with a lap when its transponder crosses the Start/Finish Line after completing one entire lap of the Track.

4.2.3.2. A kart is the first kart out of the Race and is awarded the final position based on the following order:

4.2.3.2.1. The kart is listed in the official Qualifications posting, but it is not in position in the Starting Lineup on the Grid and does not start a Race.

4.2.3.2.2. The kart is in position in the Starting Lineup on the Grid, but it does not start the Race.

4.2.3.2.3. The kart drops out during the parade or pace laps.

OR

4.2.3.2.4. The kart drops out of a Race before completion of the first lap.

4.2.3.2.5. In the event that more than one kart is affected in one or more of the above categories, such karts will be ranked based on their positions in the original Starting Lineup.

4.2.3.3. Once the competition review (time period to allow for protests, see Rule 7.3) and post-race technical inspection is completed, PGPF will post official results.

4.2.3.4. Karts not completing the scheduled number of laps will be ranked in order by total laps completed and sequence of completion, whether the kart is still running or not.

4.2.4. **Ties**

4.2.4.1. In the event that PGPF is unable to conclusively determine any difference in the physical sequence for two or more karts at the end of a Race, PGPF shall determine the finishing positions based upon the karts' positions at the start/finish line on the prior lap.

4.2.4.2. In the event two or more karts post the identical number of laps led in a Race, the kart finishing the Race in the higher/highest position will earn the award for most laps led.

4.2.5. **Shortcuts** - A kart may not improve its position with all 4 wheels off the racing surface unless there is a dangerous condition present.



4.3. RACE START

- 4.3.1. Once a kart enters the pits on race day it may not leave the track entrance gates unless instructed by the race director(s) or safety officials. If not instructed, doing so disqualifies the kart.
- 4.3.2. All karts will be lined up in pairs in the pits in their order of qualifications. When all karts are in order the crews will push them out to the track to the start/finish line.
- 4.3.3. The pole position kart will start from the inside of the front row. Each kart must be in position in the Starting Lineup during the parade and pace laps until declaration of the Green Condition.
- 4.3.4. If a kart is not in position prior to the beginning of the pace lap, the kart must start from pit lane.
- 4.3.5. If a kart fails to start in 15 seconds it must immediately return to the pits. The crew may attempt to restart the kart and the driver may rejoin the field at the rear of the starting lineup.
- 4.3.6. If a kart directly in front of you falls out of line, wait until the starter signals you to move up into their position. All karts starting on the inside remain on the inside and all karts starting on the outside remain on the outside.

4.4. MECHANICAL CONDITIONS

- 4.4.1. The Race Officials and Technical Inspectors shall determine whether a kart involved in a crash or with a hazardous mechanical condition will be permitted to continue in the event or must first return to the pit lane for necessary repairs.
- 4.4.2. Parts damaged during the race may only be replaced by an exact matching part or assembly.
- 4.4.3. After any repairs have been completed, the kart is subject to visual or other inspection by PGPF prior to and/or during any further competition.

4.5. PIT PROCEDURES

4.5.1. Pit Spot Assignments

- 4.5.1.1. Pit spots are available on a first come, first serve basis for all events except for the main race.
- 4.5.1.2. The first 27 qualifying karts will be assigned pit spots prior to race day by order of qualification time.
- 4.5.1.3. The remaining 6 qualifying karts will be assigned pit spots on race day by order of sprint race placement (see appendix O).



4.5.2. A kart must only use its specified pit box on race day unless otherwise approved.

4.5.3. Pit Speed

4.5.3.1. Drivers may not exceed 15mph in the pit lane during the race and 10mph during all other events, including practices.

4.5.3.2. Drivers in violation of 4.5.3.1. shall incur a 10 second penalty per offense added to their finishing time.

4.5.3.3. Drivers must reduce to pit speed prior to crossing the pit entry line.

4.5.4. All karts must stay in the driving lane except when entering or exiting their own pit. The exiting driver must yield to a moving kart.

4.5.5. All karts must make a pit stop during the course of the main race. During the mandatory pit stop, each kart must come to a complete stop in their designated pit area. This stop will be monitored by a PGPF member and will result in a black flag if not followed properly.

4.5.6. Tank Exchange

4.5.6.1. A fire extinguisher must be readily accessible throughout the duration of the fuel tank exchange.

4.5.6.2. Quick-fill systems, including commercially manufactured dry break systems, are not allowed.

4.5.7. All equipment and karts must be readily available for inspection at all times. All equipment/parts must be taken into the pits through the main gates. Failure to do so will result in disqualification for the remainder of the day's activities and the next running day, at the discretion of the Race Director(s).

4.5.8. Chairs are not allowed in the pits.

4.5.9. All karts, equipment, and crew members must fit in the team's designated pit box. Pit lane must be clear at all times.

4.5.10. Crew chiefs are the only member of the team who is allowed to leave their designated pit box. All other members are required to stay in the pit box at all times unless retrieving a disabled kart.

4.5.10.1. Members retrieving a kart are not permitted to enter the track area. A disabled kart will be brought to the end of the pits for retrieval by the members in the pits.

4.5.11. Only beverages in spill-proof plastic bottles are allowed in the pits. No disposable cups or glass.

4.5.12. No food or snacks in the pits or on the track. All food must be eaten outside the track facility.



4.5.13. No power tools requiring the use of an outlet will be permitted in the pit area. Battery operated tools are permitted. Battery operated tire inflators are permitted to be used inside the track. All batteries must be charged outside the gate, battery chargers will not be allowed in the pits.



5. QUALIFICATIONS

5.1. MEETINGS

5.1.1. PGPF may hold a specific meeting prior to the start of any Qualifications. PGPF may designate the meetings as mandatory for some Members.

5.2. GENERAL

5.2.1. PGPF may penalize any member delaying or attempting to delay Qualifications.

5.2.2. Once lineup for the first Qualification heat begins on Qualification Day, the kart may not leave the track entrance gate unless instructed by the race director(s) or safety officials. If not instructed, doing so disqualifies the kart.

5.2.3. The top five karts shall be held in impound until the end of the day. A maximum of two crew members and a minimum of one crew member must be with the kart at all times in impound.

5.2.3.1. Karts not in the top five must stay in the pits for the remainder of the Event with fire extinguisher, starter, and minimum one member of the team. Teams placing 6th & 7th place will also remain in the pits with a PGPF representative.

5.3. QUALIFICATION ORDER

5.3.1. Heat race order will be determined by karts being placed in groups of ten (10) based on fastest lap time set in practice. Within those groups of ten (10), groups of five (5) will be randomly generated to form the qualifying heats. Qualifying heats will go in order of generation.

5.4. WARM-UP PRACTICES

5.4.1. There shall be one half hour practice on Qualification Day for karts to warm up.

5.4.2. Odd numbered karts will be allowed to warm-up during the first 15-minute period and even numbered karts will be allowed to warm-up during the second 15-minute period.

5.4.3. When warm-up is complete, all karts will proceed to the pits to await further instructions.

5.5. DRIVERS

5.5.1. One individual registered team driver or a back-up driver can qualify only the kart registered to the team, provided the driver has met all necessary requirements.

5.5.2. If, for some unforeseen reason, the qualifying driver is unable to drive the kart on Race Day, the Race Director(s) must be notified in writing and shall decide if the reason is acceptable. If acceptable, the kart will start with the new driver and be placed at the back of the starting field.



5.6. QUALIFYING PROCEDURE

- 5.6.1. All teams must remain in the pits until instructed by race officials.
- 5.6.2. Each qualification heat will be lined up in the area indicated by race officials.
- 5.6.3. A race official will instruct each kart to start their engine one at a time and give the signal to proceed onto the track. If a kart does not start within 5 seconds, the remaining teams in the qualifying session will be released and that kart must return to its pit box. The kart will be allowed to leave the pit box and complete the qualification heat should the team be able to get the kart started.
- 5.6.4. A qualification heat will last 5 minutes.
- 5.6.5. The time of the last initiated lap before the five minutes is up will be the time of the last lap scored.
- 5.6.6. Drivers may use the pit during their heat.

5.7. DELAYS/POSTPONEMENT

- 5.7.1. In the event that not all teams can qualify on qualifications day the entire field will requalify on the rain date.
- 5.7.2. In the event that qualifications are not able to be held, starting positions in the main race and sprint races shall be set using practice results. The fastest complete lap time from a practice session will serve as qualification time for each kart.

5.8. NUMBER OF ATTEMPTS

- 5.8.1. Each team will be allowed one 5-minute session for qualification.

5.9. OFFICIAL QUALIFYING TIME

- 5.9.1. The official qualifying time is the fastest single lap time that the driver posts during his/her qualifying session. In the case of two karts qualifying with the same time, the kart which posts that time first will be placed ahead of the other kart.

5.10. QUALIFYING POSITIONS

- 5.10.1. After all teams have had the chance to qualify, the fastest kart and driver will be awarded the pole position.
- 5.10.2. The next fastest twenty-six (26) teams will be in the main event in the order of their time.
- 5.10.3. Any team/kart not making the top 27 positions after qualifying will be split up into three sprint races to take place before the main event on race day. The top two finishers from each sprint race will be added to the end of the starting lineup for the main event.
 - 5.10.3.1. Sprint race lineups will be determined by qualification position. See Appendix M.



5.10.3.2. To qualify for the sprint races, each team must either attempt a lap during their qualifying session or notify a race director if they are unable to do so. The race director may then waive their qualifying attempt.

5.10.3.2.1. An attempt is defined as an intact kart with a driver lining up at the start line for its designated qualification heat and attempting to start the engine.

5.10.3.2.2. Any kart that makes a successful attempt yet fails a lap will be placed at the back of the sprint races. If more than three karts fail to complete a lap, yet make an attempt, placements will be determined by practice lap times.

5.11. QUALIFICATION EXAMINATION

5.11.1. All karts must submit to an examination of the fuel used during any qualification attempt. Failure will result in nullification of qualification time.

5.11.2. Teams must demonstrate that the kill switch of the kart is in working condition when they return to their pit box at the conclusion of their qualification attempt. Teams who fail the kill switch inspection will have their qualification times negated. Any kart that fails the kill switch inspection will be required to demonstrate the operation of the switch prior to further participation.

5.11.3. Any qualifying engine may be subject to tear down.

5.11.4. The top five engines may be required to submit to an engine inspection immediately following qualifications at the discretion of the Safety Committee.



6. PENALTIES

6.1. GENERAL

6.1.1. PGPF may penalize any Member for any violation of the Rules. If an Official observes or is made aware of an act or omission by a Member that constitutes a violation of the Rules, the Official shall promptly report the violation to PGPF. PGPF shall consider the report and shall conduct whatever additional inquiry it deems appropriate under the circumstances. After concluding the inquiry, PGPF shall determine whether disciplinary action is appropriate and if so, what disciplinary action should be taken. The Member shall be informed of the determination and if disciplinary action is imposed, PGPF shall issue a penalty notice to the Member specifying the violation, a brief statement of the circumstances of the violation, and the penalty imposed. If the act or omission of a Member is determined by PGPF to constitute a threat to the integrity or safety of the Event, PGPF may take immediate action against the Member.

6.2. SCOPE OF PENALTIES

6.2.1. If a penalty is assessed during the course of the Main Feature or a Sprint Race, the crew chief of the penalized kart will be notified immediately by the Pit Coordinator. It is the decision of the Race Director(s) if a kart should be brought in, or if the crew chief notification is sufficient.

6.2.2. Violations of Race Procedures generally result in penalties imposed during on-Track activity.

6.2.2.1. **Black Flag** - PGPF may impose black flag penalties.

6.2.2.1.1. If a team receives three black flags during an event, they may be disqualified from the event at the discretion of the race directors.

6.2.2.1.2. These black flag infractions will be recorded by a member of the foundation and be updated during each Grand Prix event.

6.2.2.1.3. If a team is disqualified from a practice, they will be prohibited from attending the subsequent event, and their laps will not be recorded.

6.2.2.2. **Laps** - PGPF may impose lap penalties. Lap penalties shall be imposed in complete laps only. The imposition of a lap penalty shall result in the removal of official credit for the specified number of penalty laps from the total laps credited to the Competitor and the scoring records and all points and awards shall reflect the removal of penalty laps.



- 6.2.2.3. **Time** - PGPF may impose time penalties. The imposition of a time penalty may result in the removal or addition of the specified amount of time to the Competitor and the timing and scoring records and awards shall reflect the removal or addition of time.
- 6.2.2.4. **On-Track Repositioning** - PGPF may impose a repositioning penalty during on-Track activities. The reposition penalty will result in an order change of the kart's on-Track position.
- 6.2.2.5. **Disqualification** - PGPF may disqualify the Member. Disqualification shall entail the loss of any right to compete in the remainder of the current Event from the time at which the disqualifying condition first occurred.
- 6.2.3. Violations of non-Race procedures generally result in penalties imposed during off-Track activity.
- 6.2.3.1. **Additional Appearances and/or Meetings** - PGPF may require a Member to attend and actively participate in appearances and/or meetings in addition to those required of the Member pursuant to the Rules and any other agreements. PGPF may specify the due date for completion. Failure to attend and/or participate by the due date may result in reinstatement of the monetary fine if a monetary fine was imposed, or additional penalties as determined by PGPF.
- 6.2.3.2. **Monetary Fines** - PGPF may impose monetary fines and specify a payment deadline. Failure to pay any imposed fine may result in the disqualification of a team from the Event.
- 6.2.3.2.1. Monetary fines must be paid via cash or check to the Purdue Grand Prix Foundation through the Business Office for Student Organizations.



7. PROTESTS

7.1. GENERAL

7.1.1. Protests shall be submitted in writing to the Race Director(s) using official forms provided by PGPF. See Appendix C

7.1.2. A \$50 protest fee shall accompany the forms and will be returned if the protest is found to be accurate.

7.1.3. All karts involved in a protest will be impounded until final action of the Safety Committee.

7.1.4. A decision will be made by the reviewing body and a written statement will be delivered to all relevant parties on the final ruling.

7.2. TYPES OF PROTEST

7.2.1. **Scoring Protest** - A protest on the unofficial results of qualifications, sprint races, or the main event.

7.2.1.1. The reviewing body shall be composed of the Scoring Director(s), Race Director(s), and the Internal Vice President.

7.2.2. **Technical/Safety** - A protest between karts in sections 9 (TECHNICAL REQUIREMENTS) or 10 (SAFETY EQUIPMENT) of these rules.

7.2.2.1. The reviewing body shall be the Safety Committee.

7.2.3. **Competition** - a protest between karts on any of these rules not included in sections 9 (TECHNICAL REQUIREMENTS) or 10 (SAFETY EQUIPMENT).

7.2.3.1. The reviewing body shall be the Race Director(s) and the Internal Vice President.

7.3. DEADLINES

7.3.1. Sprint race protests must be submitted within five minutes of the completion of that race.

7.3.2. Main event protests must be submitted within one hour after the completion of the race.



8. APPEALS

8.1. APPEALS TEAM MAKEUP

8.1.1. The Appeals Team is made up of four voting and four non-voting members.

8.1.1.1. Voting members are one Purdue Director of Student Involvement, Student Activities and Organizations Representative and two appointed Racing Experts.

8.1.1.2. Non-voting members are the Internal Vice President, two Race Directors, and one Safety Team Member. In the event that there is a tie, the Internal Vice President will become a voting member.

8.2. DETAILS

8.2.1. Any competitor may appeal any penalty or decision assessed during technical inspection, qualifications, pre-race or post-race.

8.2.2. All appeals will be heard, reviewed, and decided by a third-party appeals team. The original decision shall remain in effect until the decision of the appeals team is rendered.

8.2.3. The appeals form must be submitted in writing to the Race Director(s) accompanied by a \$200 appeal fee within the time limit (as defined in 8.3) after rendering of the protest decision. This paperwork is to include a copy of the original appeal and reasons for appeal. See Appendix D.

8.2.4. Upon receipt of the appeal, the appeals team will meet to review the infraction versus the rule(s) in question. The voting members will make their decision based on the written rules. They may ask the race directors, Race Official or race team questions during their review if they so desire. Upon making their decision, they will discuss with the race directors and Race Officials to assure the resulting decision backs up the written rules.

8.2.5. Once the appeal decision is finalized, a short-written appeal decision will be submitted to the race directors. The race directors will then relay the appeals team decision to the race team.

8.2.6. The third-party appeals team may confirm, reduce, or waive the original protest decision. The appeal fee will be returned to the race team if the protest decision is reduced or waived.

8.2.7. The decision of the third-party appeals team is final.

8.3. APPEAL TIMING

8.3.1. Time to appeal protest decision:

8.3.1.1. Technical Inspection - 8 hours.

8.3.1.2. Qualifications - 8 hours.

8.3.1.3. Pre-race - 30 minutes after the final sprint race.



8.3.1.4. Post-race - 1 hour.

8.3.2. Time for appeals team to render decision:

8.3.2.1. Technical Inspection - 8 hours.

8.3.2.2. Qualifications - 8 hours.

8.3.2.3. Pre-race - 30 minutes.

8.3.2.4. Post-race - 6 hours.



9. TECHNICAL REQUIREMENTS

9.1. PRE-RACE INSPECTION

- 9.1.1. All karts and supporting equipment must pass technical inspection before participation in practice, qualifications, or the race.
- 9.1.2. No changes may be made to the karts or supporting equipment after passing technical inspection except: paint or decals for Race Day or repairs due to an accident. Passing technical inspection does not guarantee compliance with these rules.
- 9.1.3. A kart may be protested and/or disqualified because of noncompliance with any rule in this package per discretion of PGPF.
- 9.1.4. Kart and driver set-up must not deviate significantly after passing technical inspection to the point that the kart becomes noncompliant.
- 9.1.5. Karts must always comply with the rules.
- 9.1.6. The Safety Committee has the right to inspect any kart at any time for any reason.
- 9.1.7. Each kart will be allowed a total of two scheduled inspection times. Failure to pass the second technical inspection may result in disqualification from the Event. A kart must be fully assembled to pass tech.
- 9.1.8. If any previously approved piece of a kart breaks after the second inspection, teams must show evidence of the break before having the new piece re-inspected.
- 9.1.9. Only members of the crew can be present during the technical inspection process. Nonmembers of kart teams may stay in the designated drop off point but may not enter the inspection area. If anyone other than crew members are present during the inspection process, the team's kart will be disqualified, as determined by the Grand Prix Race Director(s).

9.2. POST-RACE TEAR DOWN INSPECTION

- 9.2.1. The karts finishing in the first five positions at the end of the race shall submit to a mandatory engine tear down performed by a third-party inspector. Drivers and karts placing in these positions must go directly to the designated impoundment location without stopping in their pit box.
- 9.2.2. Karts placing sixth to tenth must remain at the track (with a PGPF representative) and available to come to tech should anyone fail the tech inspection. Should any of those placed sixth to tenth leave the track after the completion of the race, they will forfeit their right to enter the top five.



9.2.3. Any other impounded karts may be required to submit to this tear down during the impoundment period.

9.2.4. All crews shall be responsible for any modifications found during tear down.

9.2.5. Teams are required to provide all required tools for their own engine tear down.

9.2.6. Refusal of the crew chief to disassemble the kart or engine shall result in immediate disqualification.

9.2.7. Qualification engines may be marked for identification.

9.2.8. If a kart should use a different engine in the race than was used for qualifications, then the qualification engine shall be brought to the tear down in addition to the race engine.

9.2.9. During inspection of the engine, only one member of the official crew and the driver of the kart being inspected may be present with the inspector. Any other unofficial member or outside personnel present in the inspection area at the time of inspection will lead to that team's disqualification, as determined by the Grand Prix Race Director(s).

9.2.10. The third-party inspector's decision is final. See Appendix L for the Post-Race Tear Down Inspection Checklist.

9.2.11. Karts failing the Post-Race Technical Inspection will be disqualified and their finishing position will be forfeited.

9.3. MATERIAL SPECIFICATION

9.3.1. The following material specifications may be changed if prior written approval is secured from the technical inspectors.

9.3.2. SPEC 1

9.3.2.1. 1" by 0.083" wall thickness seam welded or seamless round steel tubing.

OR

9.3.2.2. Unbent 1" by 0.083" wall thickness radius corner square seamed welded or seamless steel tubing.

OR

9.3.2.3. 1" by 2" by 0.083" wall thickness rectangular steel tubing.

OR

9.3.2.4. 1" by 0.125" wall thickness seam welded or seamless round 6061-T6 Aluminum tubing.

OR

9.3.2.5. 1.125" by 0.083" wall thickness welded or seamless round 6061-T6 Aluminum tubing.



OR

9.3.2.6. 1.25" by 0.083" wall thickness welded or seamless round 6061-T6 Aluminum.

9.3.3. SPEC 2

9.3.3.1. 18 gauge or heavier sheet steel or aluminum.

9.3.4. SPEC 3

9.3.4.1. SAE class five (5) bolt is a six-line cap screw.

OR

9.3.4.2. Metric Class 10.9 or 12.9 cap screw (NOT 8.8).

9.3.5. SPEC 4

9.3.5.1. Lightweight aluminum (16-24 gauge) is the only material allowed for use as fairings, cowlings, and shields.

9.3.6. SPEC 5

9.3.6.1. Any mounting other than a welded tab is subject to the discretion of the safety and race officials.

9.3.7. SPEC 6 - Allowable Plastic Items

9.3.7.1. To reduce fire hazard the only plastic items allowed on the kart are:

9.3.7.1.1. The seat.

9.3.7.1.2. Number panels.

9.3.7.1.3. Mirrors.

9.3.7.1.4. Cable ties.

9.3.7.1.5. Commercially manufactured clutch scoops.

9.3.7.1.6. Chain guards.

9.3.7.1.7. Engine information display monitor.

9.3.7.1.8. Upper and lower steering block.

9.3.7.1.9. Cameras and camera mounting brackets.

9.3.7.1.10. Fuel filters.

9.3.7.1.11. Airbox and filter (silencer).

9.3.7.1.12. Transponder and mounting bracket.

9.3.7.1.13. Data logger.

9.3.7.1.14. Chain oiler.

9.3.7.1.15. Throttle cable guides.

9.3.7.1.16. Commercially manufactured floor pans.

9.3.7.1.17. Commercially manufactured front, rear, and side bumpers.



9.3.7.1.18. Column/steering fairings.

9.3.7.2. Exceptions to this rule can be made if documented proof of fire retardancy from the manufacturer is provided and approved by a variance form (Appendix B) through the Safety Committee. This documented proof must be present at all times.

9.3.8. **SPEC 7 - Composite Materials**

9.3.8.1. The use of composite materials, including, but not limited to, carbon fiber, fiberglass, Kevlar, will not be allowed on karts unless otherwise indicated in the rules and specification or as deemed appropriate by the Race Officials. Decorative stickers made to look like carbon fiber weaving or similar should be easily identified as being a sticker and that the material underneath meets all requirements.

9.4. **KART SPECIFICATIONS**

9.4.1. All subsequent rules in this section will be interpreted by the technical inspectors who, along with the Race Director(s), will determine the acceptability of each kart.

9.4.2. **Inspection Stickers**

9.4.2.1. The inspection sticker, indicating a kart has been accepted, shall be positioned at a conspicuous place on the kart chosen by the Race Director(s) at technical inspections.

9.4.3. **Main Frame**

9.4.3.1. Generally, stock commercially manufactured sprint kart frames will be acceptable.

9.4.3.2. No enduro or lay down karts will be allowed to enter the race.

9.4.3.3. Nerf bars are a required part of the kart frame.

9.4.4. **Safety Frame**

9.4.4.1. **Roll Bar/Cage**

9.4.4.1.1. The roll bar must meet or exceed material Specification 1.

9.4.4.1.2. It must be of such a design to enclose and protect the driver in case of rollover.

9.4.4.1.3. All cages must be of at least a four-point design and have gussets at each intersection of the roll bar and the roll cage.

9.4.4.1.4. Two points must extend in front of the driver to prevent any large obstacles from coming in contact with the driver.

9.4.4.1.5. Gussets are to be at least the same thickness as the wall thickness of material Specification #1 and at least be two (2)" long by two (2)" high.

9.4.4.1.6. The roll bar must be of one (1) piece construction and be a minimum of eight (8)" wide or have a minimum radius of four (4)" at its highest point.



9.4.4.1.7. Gussets may also be required at other areas of structural concern as determined by the Technical Inspectors.

9.4.4.1.8. No part of the driver's body may stick out from the roll cage.

9.4.4.1.9. There must be a four (4)" clearance from the helmet to the top of the cage and all around the helmet.

9.4.4.1.10. The roll cage must be attached to the main frame.

9.4.4.1.11. Bolt heads should be on the outside of the cage.

9.4.4.2. Bumpers and Side Bars

9.4.4.2.1. Bumpers, side protection bars, and attachments to the frame must meet or exceed material Specification 1.

9.4.4.2.2. Bumpers and sidebars must be six (6)" minimum effective height as measured from the top of the bumper to the bottom of the bumper and must be in a vertical line with each other.

9.4.4.2.3. Bottom bars must be seven (7)" or less above the ground and top bars must be six (6)" or more above the bottom bar.

9.4.4.2.4. Distances shall be measured from the centerlines of the bars.

9.4.4.2.5. Bumpers must be designed so that the bumper of another kart will not pass through them.

9.4.4.2.6. Bumpers and side bars must not extend beyond the outside edge of the tires physically on the kart.

9.4.4.2.7. The bumpers and sidebars must be connected with metal material to prevent bumper hooking.

9.4.4.2.8. Bumpers must be attached to the main frame of the kart.

9.4.4.2.9. CIK Approved plastic rear bumpers may take place of metal bumpers as described in 9.4.4.2. so long as they are installed to manufacturer specifications.

9.4.4.2.10. Plastic side bumper and plastic front bumper panels must be placed over the metal side bumpers and front bumper as described in 9.4.4.2. and secured as designed by the manufacturer of the panels.

9.4.4.3. Foot and Leg Protection Bars

9.4.4.3.1. Foot and leg protection bars and braces must meet or exceed material specification #1 and be an integral part of the roll cage, i.e., welded to the sidebars or bumpers.



9.4.4.3.2. Leg and foot protection bars shall be attached to the side rails such that one bar passes over the knees. There must be a minimum clearance of two (2)" over the top of the knees.

9.4.4.3.3. The bars must be braced forward to the front bumper by two or more braces.

9.4.4.3.4. Adequate protection bars must be provided to prevent another kart from penetrating the driver's compartment. A guard must prevent the driver's feet from touching the ground.

9.4.4.3.5. Plastic column fairings must be installed to manufactured specifications with safety wire through each bolt.

9.4.4.4. **Roll Cage Attachment**

9.4.4.4.1. The roll cage must be bolted and cotter pinned or wired securely to the frame by at least one (1) point in the front and one (1) point in the rear.

9.4.4.4.2. A minimum 3/8" Grade 5 bolt is required.

9.4.4.4.3. These mounts must be located along the geometrical center of the kart if only one mounting bracket is being used.

9.4.4.4.4. Heim Joint fastener threads must be a minimum of 3/8" in diameter.

9.4.4.4.5. No elastic straps or cord will be allowed.

9.4.4.4.6. All roll cage attachment bolts must be visible for inspection.

9.4.4.5. **Construction of Safety Frame**

9.4.4.5.1. All open tubing shall be caulked 1" deep or plugged with rubber or similar materials. All plugs must be secure and in good condition.

9.4.4.5.2. The safety frame shall be completely smooth; all rough surfaces shall be filed.

9.4.5. **Use of Mounting Blocks**

9.4.5.1. Mounting blocks are approved for use in attachment of the safety frame, muffler, fuel tanks, and other areas provided:

9.4.5.1.1. All bolts must pass completely through the block with nuts and cotter pins (or safety wire) on the back side

9.4.5.1.2. Any bolts used to attach the safety frame must meet the safety frame attachment specs above

9.4.5.1.3. Any blocks used to attach the safety frame must completely enclose the bars with bolts on both sides, not simply "clamp" onto the frame.

9.4.6. **Wheelbase**



9.4.6.1. The Wheelbase of the kart shall be between 40" and 66" measured from the axle centers

9.4.7. **Kart Width**

9.4.7.1. The total width of the kart shall be at minimum of 30" and a maximum of 55 1/8" outside to outside of tire or kart.

9.4.8. **Tires**

9.4.8.1. Tire softener will not be allowed anywhere on the premises.

9.4.9. **Wheels**

9.4.9.1. Axle nuts shall be castellated and secured with cotter pins or as the manufacturer intended.

9.4.9.2. Safety wire or bolts through the axle are not acceptable

9.4.9.3. All wheels shall be of racing quality and void of any defects.

9.4.10. **Seat Back and Floor Pan**

9.4.10.1. The floor pan must meet or exceed material Specification 2.

9.4.10.2. Seat shall be a molded, one-piece sprint bucket design and be the correct size for the driver so they cannot move or slide from side to side in a manner that could be unsafe. Commercially manufactured fiberglass or carbon fiber seats are required. (See Appendix G).

9.4.10.3. Lay down type seats are illegal (See Appendix G).

9.4.10.4. Seat cannot be cut in any way to add or remove material and shall be in safe condition, e.g., the bottom is not weak or broken. Final decision will be determined by the Race Directors and/or Race Officials.

9.4.10.5. Bottom of seat shall be between the frame rails and either mounted flush with or above the frame rails. Seat shall be mounted to the kart in a minimum of four spots with front of seat being higher than the bottom. Adjustable seats that can be moved while on track are illegal.

9.4.10.6. The integrity of the tubing material may not be compromised, flat stock will not be permitted for the seat mount.

9.4.11. **Headrest and Harness Support**

9.4.11.1. Padding the safety cage alone will not be an acceptable headrest system meeting the performance criteria of this rule.

9.4.11.2. A headrest and harness support system must be provided with the following features:



9.4.11.2.1. Must meet or exceed material Specification 1.

9.4.11.2.2. Must keep the head in alignment with the spinal column in a neutral position without pushing the head forward or allowing it to extend backward.

9.4.11.2.3. May not be part of, supported by, or attached to the roll cage (safety frame).

9.4.11.2.4. Typically, should be mounted to the shoulder belt support, although it can be attached separately to the kart main frame depending on the design.

9.4.11.2.5. The headrest must provide a flat area with a minimum dimension of 6" across to maximize contact with the helmet.

9.4.11.2.6. Must be padded with rubber, foam, or other shock absorbing materials

9.4.11.2.7. Must be 1" minimum thickness with no sharp edges exposed.

9.4.11.2.8. The center back area of the helmet shall make contact with the center point of the headrest.

9.4.11.2.9. An adjustable height headrest is recommended to accommodate drivers of different heights and must be secured by a bolt with a cotter pin.

9.4.11.3. Seating the driver and relief driver in the kart with their helmet on will be the method used to assess the headrest during inspection.

9.4.12. Fuel Tank

9.4.12.1. Exchange fuel tanks are mandatory. No other fuel system will be allowed.

9.4.12.2. Fuel tanks must be completely protected by the safety frame.

9.4.12.3. The fuel tank must be of racing quality as determined by the technical inspectors.

9.4.12.4. Only one (1) fuel tank of seven (7) quart maximum capacity is permitted on the kart at any time.

9.4.12.5. Fuel tanks must have an accessible valve attached to the tank, which positively shuts off fuel flow at the point of discharge.

9.4.12.6. A firewall (splash shield) must enclose three sides, the bottom and the rear of the fuel tank; the height of the firewall must be at least 3/4" higher than the height of the fuel tank.

9.4.12.7. All edges of the firewall must be rolled, folded under, or cornered with rubber or comparable material for maximum safety.

9.4.12.8. *Design Engineering* 050501 or similar shielding is permitted on the interior of the firewall. Other types of firewall lining must be approved by a race official.

9.4.12.9. The firewall must be securely attached to the nerf bars or main frame.



- 9.4.12.10. The fuel tank must be mechanically secured in such a way that if the connector between the tank and the fuel line is breached the tank will remain in position (i.e. a safety pin in addition to the quick disconnect). This additional securement should be tethered.
- 9.4.12.11. Fuel tanks must incorporate either a check-valve or an approved vent relief cap into the vent system. This means the fuel fill cap must be positively sealed so the fuel tank is vented to the atmosphere through the check valve or vent relief cap.
- 9.4.12.12. The venting mechanism must be installed in a safe manner as determined by the technical inspectors.
- 9.4.12.13. No silicon rubber will be permitted, and hose barbs should be silver soldered to the vent cap.
- 9.4.12.14. Venting mechanism must not allow any flow of gasoline.
- 9.4.12.15. Any check valve or vent relief cap not properly functioning will need to be immediately removed from the track.
- 9.4.13. Exchangeable Fuel Tanks**
- 9.4.13.1. Exchangeable fuel tanks are fuel tanks that can be removed and replaced with an exact duplicate.
- 9.4.13.2. Elasticized fasteners will not be allowed to secure fuel tanks.
- 9.4.13.3. The design and the final product must be approved by the technical inspectors before being used but technical approval of the tank in no way indicates approval of the volume.
- 9.4.14. Fuel Lines**
- 9.4.14.1. Commercial, metal worm-gear hose clamps shall securely clamp all fuel lines at both ends of each section.
- 9.4.14.2. All fuel system components except for the tygon tubing and the vent components, must be made of a metal material.
- 9.4.14.3. Fuel lines shall be gasoline tygon tubing in good condition.
- 9.4.14.4. Fuel lines will be no longer than necessary to cover the distance from the fuel tank to the engine.
- 9.4.14.5. Fuel filters may be no larger than normal small engine filters.
- 9.4.14.6. Fuel lines must be fastened below the seat, above the frame, and must not go over the driver.
- 9.4.15. Throttle**



9.4.15.1. Karts shall be equipped with a foot-operated throttle with two return springs, which will close the throttle when the pedal is released. One spring must be on linkage at the point of contact to the frame.

9.4.15.2. The Safety Committee must approve any exceptions through a variance form.

9.4.16. Brakes

9.4.16.1. All karts shall have pedal operated brakes operating in such a manner as to brake both rear wheels equally.

9.4.16.2. Brake linkages must have at least two (2)" clearance off the ground.

9.4.16.3. A cotter pin must be placed through the pivot pin, which connects the brake linkage lever to the master cylinder.

9.4.16.4. Disc brake discs must be at least 1/8" thick.

9.4.16.5. Brakes must be able to lock both rear wheels at maximum speed.

9.4.17. Clutches

9.4.17.1. All karts shall be equipped with a clutch, which will allow the kart to stand still with the engine running.

9.4.17.2. Third bearing support is required.

9.4.17.3. Must be attached with a minimum of two bolts with drilled heads and safety wired to each other.

9.4.17.4. No axle clutches are allowed.

9.4.18. Gearboxes

9.4.18.1. Selective gearboxes or other transmission devices are permitted as long as no oil leaks from the device.

9.4.18.2. There is no maximum gear ratio.

9.4.19. Chain Guard

9.4.19.1. Karts shall be equipped with a chain, belt, or gear guard to eliminate possibility of personal injury, covering all pinch points.

9.4.19.2. The gear guard must be at least equal in diameter to the gear used.

9.4.20. Chain Oilers

9.4.20.1. If applicable, a chain oiler shall have a maximum capacity of eight ounces and must be properly hardware mounted and safely tied so that it does not allow fluids to spill on the track.

9.4.21. Steering



9.4.21.1. The steering shall be direct acting and of suitable design for maximum safety and prevention of over center lock.

9.4.21.2. The steering shaft shall be solid steel of minimum diameter of 5/8" or tubular steel of minimum diameter 19 mm.

9.4.21.3. The steering wheel hub shall be secured to the shaft by a cotter pin, castellated nut.

9.4.21.4. All steering assembly bolts shall be grade 5 or higher and a minimum of 1/4" in diameter.

9.4.21.5. All steering assembly nuts shall be castellated, and cotter pinned or safety wired.

9.4.21.6. All rod ends shall be protected from collision.

9.4.22. Steering Wheel

9.4.22.1. The steering wheel shall be attached to the hub by at least three cotter pin bolts with cotter pinned nuts or by bolts with safety wired heads if a thread hub is used.

9.4.22.2. Any sharp protrusions shall be covered, but all nuts and bolts must be available for inspection.

9.4.23. Front Spindle and Rear Axle

9.4.23.1. The front spindle and rear axle shall not extend beyond the wheel widths.

9.4.23.2. The rear axle shall be at or between 30 and 50 mm in diameter and be either steel or aluminum or approved equivalent construction and strength.

9.4.24. Exhaust System

9.4.24.1. Mufflers shall be on all karts securely mounted and cotter pinned.

9.4.24.2. All portions of the muffler shall be contained inside the roll cage and not be attached to it.

9.4.25. Welds

9.4.25.1. Only welds of high quality, as determined by the Race Officials, shall be acceptable.

9.4.25.1.1. Failure to comply may result in disqualification

9.4.25.2. All new construction or repairs must be TIG welds.

9.4.25.3. Butt welds must be reinforced by an inner sleeve at least twice the tubing diameter in length.

9.4.25.4. One 1/8" hole per weld must be drilled into the sleeve area to indicate the presence of the sleeve.

9.4.25.5. Any non-factory frame welds must be clean and unpainted for any inspection.

9.4.25.6. No plastic body filler or lead will be allowed in seams.



9.4.26. Castellated Nuts and Cotter Pins

9.4.26.1. Kingpins, pedal attachment points, steering wheel bolts, seat belt fastenings, fuel tank mountings, safety frame, and all parts of the brake, throttle, and steering linkages shall be cotter pinned.

9.4.26.2. All cotter pins shall fit snugly in the holes and pass through the nuts or through the serrated sections of castellated nuts.

9.4.26.3. All other bolts must be at least Grade 5 and cotter pinned or secured with safety wire passing through the bolt, with the following exceptions:

9.4.26.3.1. Engine bolts other than third bearing bolts.

9.4.26.3.2. Rear axle hubs, sprockets, and brake rotor assemblies.

9.4.26.3.3. Any generally inaccessible bolts (i.e. Rear wheel lugs) subject to the discretion of the safety committee.

9.4.26.4. No nylon-fiber locknuts are allowed except in use with the engine mounts, chain guard, and floor pan. The front axle nuts must be cotter pinned.

9.4.26.5. Distorted nuts may be used; however, they still must be pinned or wired.

9.4.26.6. Circlips are an acceptable substitution for cotter pins and safety wire provided the bolt is designed for circlips.

9.4.27. Kill Switch

9.4.27.1. All karts shall be equipped with a toggle cut off switch that will disrupt the ignition spark and shut off the engine.

9.4.27.2. The switch shall be mounted on the steering column brace by the steering wheel or on the steering wheel with easy access.

9.4.27.3. The kill switch shall be a single pole, single throw switch.

9.4.27.4. Kill Switch must be demonstrated at Tech Inspections and Qualifications.

9.4.28. Starters and Batteries

9.4.28.1. All starter motors shall have a workable on/off switch. Wiring on these motors shall have standard battery connections so as to provide spark-free operation.

9.4.28.2. Starter motors shall be an inspection item.

9.4.28.3. Starter motors must be securely attached to a battery at all times. This includes any time the starter motor is at the track.

9.4.28.4. All batteries must be in an enclosed container with a lid that is securely attached to the container at all times. A marine battery type container is strongly recommended.



9.4.28.5. Self-contained battery/starter units are acceptable only if electrical insulation is provided to the positive and negative terminals, which prevents shock hazards and any potential for shorting the battery.

9.4.28.6. All electrical connections must have a plastic cover; taped terminals will not be accepted.

9.4.29. **Kart Identification**

9.4.29.1. Numbers will be assigned on a first come, first served basis except for #1, which will be reserved for the previous year's winner. If the previous year's winner waives the reserved #1, it will be available to any team on a first come, first serve basis.

9.4.29.2. **Retired Numbers**

9.4.29.2.1. Numbers that are retired cannot be used in any PGPF event. The list of retired numbers are as follows: #20.

9.4.29.3. **Number Panel Requirements**

9.4.29.3.1. One number panel in the front of the kart, which is readable from the front and the top (for recognition from the flag bridge).

9.4.29.3.1.1. Front number panels must be placed above the front bumper where they are not subject to damage.

9.4.29.3.2. One number panel in the rear (readable from both sides).

OR

9.4.29.3.3. A number panel placed on both sides.

9.4.29.3.3.1. Rear and side numbers must be placed high on the safety cage.

9.4.29.3.4. Number panels shall be at least seven (7)" by nine (9)" but no more than eight (8)" by ten (10)".

9.4.29.3.5. Numbers must be at least five (5)" tall.

9.4.29.3.6. White number panels are to be used by non-rookie drivers only. Yellow number panels must be used by rookie drivers and may be used by non-rookie drivers.

9.4.29.3.7. Only painted or Mylar stick-on numbers are allowed. Motor cross numbers are acceptable, but no taped numbers will be allowed.

9.4.29.3.8. All number panels shall be made of substantial material, and all edges shall be either rolled, folded under, protected with rubber or comparable material edging for maximum safety.

9.4.29.3.9. All number panels must be on the kart at all times.



9.4.30. **Wings**

9.4.30.1.1. Wings will be allowed, but the Safety Committee must approve both the plans and the final product. Wings shall not exceed the width of the safety frame.

9.4.31. **Electronic Devices**

9.4.31.1.1. The only electronic devices allowed inside the track facility are:

9.4.31.1.1.1. Approved radio equipment for communication with the driver.

9.4.31.1.1.2. Approved video cameras.

9.4.31.1.2. Electronic devices not allowed include but are not limited to:

9.4.31.1.2.1. Mobile phones.

9.4.31.1.2.2. Music players.

9.4.31.1.2.3. Apple Watches and Fitbits.

9.4.31.1.2.4. AirPods and headphones.

9.4.31.1.3. Track workers are not permitted to use any electronic device while on the track.

9.4.32. **Cameras**

9.4.32.1. Cameras found on the track may result in a \$50 fine.

9.4.32.2. Cameras are allowed on karts provided they meet the following:

9.4.32.2.1. Mounted to the kart only on the inside of the roll cage.

9.4.32.2.2. Helmet mounted cameras are only permitted during practices.

9.4.32.2.3. Cameras must be approved by the Safety Committee during technical inspections.

9.4.32.2.4. Cameras must be tethered to the kart with safety wire in addition to the camera mount.

9.4.32.2.5. Any cameras mounted after technical inspections must be approved by the safety committee.

9.4.33. **Ground Clearance**

9.4.33.1. Drive sprocket must have a clearance of at least 0.5".

9.5. **WEIGHT**

9.5.1. The combined weight of the kart and driver must always exceed 360 pounds. The minimum weight shall be measured when the kart is in competition configuration.

9.5.2. **Addition of Weight**



9.5.2.1. All non-structural weights added to meet minimum kart/driver weight requirements must be bolted securely to the main frame or floor pan of the kart, with a 1" fender washer, painted white, and clearly labeled with the kart's number.

9.5.2.2. Bolts of minimum 5/16" diameter must be used to secure weights and these bolts must be cotter-keyed or wired.

9.5.2.3. Mounting of weights to nerf bars and seats are prohibited.

9.5.2.4. No plastic containers holding water or metal pellets are allowed.

9.5.2.5. Filling the frame structure with metal pellets is prohibited.

9.5.2.6. The approval of the attachment location and manner in which the weights are attached is at the discretion of the Race Officials.

9.5.3. **Weigh In Procedure**

9.5.3.1. Each kart and driver will be weighed at tech inspection.

9.5.3.2. On qualification day, the kart and driver will be weighed before their qualification run.

9.5.3.3. At the conclusion of the race, the top 5 karts and drivers will be weighed prior to the Post Race Technical Inspection. Any top five finisher that does not meet the minimum weight will be disqualified.

9.6. **ENGINE**

9.6.1. **Eligibility**

9.6.1.1. Only the Yamaha KT-100S engine (spec per American Kart Racing Association, see Appendix I) is legal for competition in the Grand Prix. This engine is an internal combustion engine of the two stroke cycle type.

9.6.1.2. Modifications or alterations are prohibited with the exception of over-boring for wear up to, but not exceeding, a maximum bore size of 2.090 inches.

9.6.1.3. Maximum displacement is 100cc.

9.6.1.4. Internal parts may be interchanged as long as replacement parts meet stock specifications.

9.6.1.5. Only one engine may be mounted to a kart.

9.6.2. **Fuel and Oil**

9.6.2.1. Crews are responsible for providing their own fuel. However, all fuel must still conform to existing rules concerning any prohibited substances. The crew is wholly responsible for the legality of the fuel mixture used in their kart.



9.6.2.2. Any commercial oil containing special additives is not permitted. Acceptable examples are Klotz, Techniplate, Blendzall White Label, Yamalube, and TC Lubricants.

9.6.2.3. Lubricants which contain special additives such as Blendzall Gold Label, are not acceptable.

9.6.2.4. Fuels will be tested after qualifications, after all races, and at any other time for any other reason at the Race Director(s)'s discretion. Fuel testing, at minimum, will include a Digatron meter test for the dielectric constant. Fuels that read positive when tested will fail the test and not be allowed on the track. Other fuel tests, including but not limited to lab analysis, will be used at the Race Director(s)'s discretion.

9.6.3. Fuel Storage

9.6.3.1. All fuel other than the portion in the kart exchange tanks shall be stored in and dispensed from a flammable liquids safety can. A flammable liquids safety can is a vessel which contains a spring actuated dispensing spout, a flash arrester, vapor release capability and is approved by Underwriter's Laboratory, Factory Mutual or a qualified standard testing laboratory.

9.6.3.2. This rule applies to all fuel cans inside the fence perimeter. All fueling must take place outside of the track facility, with the exception of a fuel tank exchange. The fuel cans must display the inspection sticker provided at technical inspection.

9.6.3.3. All cans will be five gallons maximum.

9.6.3.4. No pressurization of any fuel tanks is permitted.

9.6.4. Silencers

9.6.4.1. All karts must be equipped with a silencer on the intake of the engine.

9.6.4.2. The silencer must be CIK approved two-hole design in accordance with standard karting specifications.

9.6.4.3. The silencer must also be secured to the frame, with a secondary tether or mount. A small hole may be drilled in the solid plastic fin of the silencer to facilitate mounting.

9.6.4.4. Any additional holes in the body of the intake will render it illegal.

9.6.4.5. The baffle tube shall have an inner diameter that is less than or equal to .905".

9.7. VARIANCE FORMS

9.7.1. The Race and Safety Committees must review any variations from the above rules.

9.7.2. Forms must be submitted within 7 days of the first technical inspection. Late submissions may not be reviewed. The Safety Committee will respond no later than 4 days prior to the second technical inspection.



10. SAFETY EQUIPMENT

10.1. All safety equipment to be used shall be brought to inspection and shall also be available for re-inspection at any time. All equipment should be reasonably clean (free of oil, gas, dust, etc.) and present at all times.

10.2. HELMETS

10.2.1. Helmets must be full faced, a minimum of Snell 2015 approved, and not older than 5 years from manufacturing date.

10.2.2. All elements of the helmet must comply with manufacturer regulations.

10.2.3. Long hair must be securely fastened beneath the helmet or jacket.

10.2.4. Helmets must meet factory conditions with no detected defects or damages

10.2.5. A sticker will be applied to the helmet at technical inspections, in a position designated by the Race Officials, to ensure the same helmet is used during practices, qualification, and the race.

10.3. DRIVER PROTECTIVE CLOTHING - All drivers shall be required to wear the following:

10.3.1. Gloves of suitable abrasion-resistant material that fully cover the wrist

10.3.2. Neck brace in good condition (i.e. no foam removed, secure Velcro, etc.), which meet the requirements of S.F.I. 3.6.

10.3.3. Full length socks that provide full ankle coverage.

10.3.4. Closed-toe, non-slip-on shoes secured by laces, buckles, or straps required. Canvas shoes will not be permitted.

10.3.5. One of the following:

10.3.5.1. A fire-retardant racing suit that meets or exceeds the SFI3-2A/5 or FIA CIK 88562000 standard (examples of certification labels can be found in the Addendum Section VI).

OR

10.3.5.2. A non-fire-retardant racing suit and at least one layer of Nomex underwear. If the driver chooses to use the Nomex underwear it must be FIA approved or contain a tag showing it contains Nomex fiber.

10.3.6. Driver protective equipment and helmet must cover all exposed skin.

10.4. CREW MEMBER CLOTHING

10.4.1. At all times within the track area all crew members must wear:

10.4.1.1. Shirts that cover entire shoulder area, chest, and stomach.

10.4.1.2. Sturdy, closed-toe shoes with heels no taller than 2 inches.



- 10.4.1.3. Full length pants (no sweat pants, no jeans with holes, no polyester or plastic clothing, no shorts, no yoga pants) and full-length socks that provide full ankle coverage.
- 10.4.2. All crew members must wear ANSI Spec Z87.1-2015, equal, or better approved safety glasses while inside track.
- 10.4.3. Final discretion of clothing allowed is determined by the Safety Committee.

10.5. FIRE EXTINGUISHERS

- 10.5.1. Each kart shall provide its own fire extinguisher, which must be brought to technical inspection, practice, qualifications, and the race.
- 10.5.2. All fire extinguishers must be:
 - 10.5.2.1. Gas Class B Underwriters Laboratory approved.
 - 10.5.2.2. A minimum of 2 & 1/2 pounds capacity.
 - 10.5.2.3. Inspected within the calendar year of the race, tagged, and sealed.
 - 10.5.2.4. Carbon Dioxide extinguishers are required.
- 10.5.3. No dry chemical extinguishers will be allowed.
- 10.5.4. All fire extinguishers within the pit area must display the inspection sticker provided at the technical inspection.
- 10.5.5. Fire extinguishers must be on hand when the kart is being started.
- 10.5.6. Fire extinguishers missing the breakaway pin seal must be re-inspected and resealed. Cable ties are NOT acceptable replacements for the breakaway seals.
- 10.5.7. Fire extinguishers may be rented from the Grand Prix Foundation for a \$50 fee. This is a one-day rental; teams are required to have their own fire extinguisher.

10.6. DRIVER RESTRAINT SYSTEMS

- 10.6.1. A driver restraint system is required on all karts.
- 10.6.2. A driver restraint system consists of lap and shoulder belts.
- 10.6.3. All belts must be securely fastened to the main frame or to a fixed bracket system.
- 10.6.4. Proper fit is at the discretion of the safety and race officials
- 10.6.5. Documented instructions from the manufacturer on the proper installation of the driver restraint systems shall be presented at technical inspection if a significant deviation from these rules exists.
- 10.6.6. **Attachments**
 - 10.6.6.1. Attachment point for the lap belt must be welded to the frame, not a clamping bracket (see appendix E).
 - 10.6.6.2. U-bolts are not allowed to attach the seat belts to the frame.



10.6.6.3. Mounting brackets should be installed at an angle that is compatible with the direction of pull on the webbing under full load (see Appendix E).

10.6.6.4. Attachment points and routing should be chosen so as to keep restraint belts at least four inches away from sources of excessive heat or abrasion at the discretion of the Safety Committee.

10.6.7. Arm Restraints

10.6.7.1. All karts must be equipped with commercially made Arm restraints with the following:

10.6.7.1.1. Must not allow the drivers arms to extend beyond the roll cage.

10.6.7.1.2. Must be placed just below the bend of the elbow of the driver.

10.6.7.1.3. Must be tight enough to not slip out of place on the driver's arm.

10.6.7.1.4. Must be a different color than the driver's suit or taped with a contrasting color tape.

10.6.7.1.5. The Arm restraints should be worn according to the manufacturer's recommendations.

10.6.7.1.6. Suit integrated Arm restraints are acceptable and must be marked with a contrasting color.

10.6.8. Belts

10.6.8.1. SFI rated belts and harnesses are required.

10.6.8.2. Safety belts are required to have a width of at least three (3)".

10.6.8.3. No belts or belt supports may be attached to or supported by the roll cage, nerf bars, or bumpers.

10.6.8.4. Under no circumstances are bolts inserted through belt webbing acceptable for mounting.

10.6.8.5. Belt webbing may be required to be replaced if the webbing shows signs of wear and tear or age.

10.6.8.6. Belts with webbing manufacture date of more than three (3) years are not acceptable.

10.6.8.7. Shoulder harness straps/belts must be positively retained to any harness support. For example, a metal rod with cotter keys on both end so that straps do not fall off of shoulders.

10.6.8.8. The shoulder harness bracket system shall be designed so that a load applied in any direction will not result in any movement of the shoulder harness bracket



10.6.9. Hardware

10.6.9.1. Commercial restraint system mounting hardware is recommended.

10.6.9.2. The minimum specification for all hardware used to attach the driver restraint system hardware is 3/8" Grade 5. This applies to ANY and ALL bolts used for the driver restraint system including any brackets.

10.6.9.3. All bolts used in the driver restraint system must be drilled and safety wired or pinned.

10.6.9.4. Documented instructions from the manufacturer on the proper installation of the driver restraint systems shall be presented at technical inspection if a significant deviation from these rules exists.

10.7. AIR TANKS

10.7.1. Any and all air tanks must be commercially manufactured and clearly labeled as a refillable vessel.

10.7.2. The tank shall be made of steel which is at least .048 inches in thickness.

10.7.3. The tank shall have a functioning pressure gauge in good condition, a pressure relief valve set at 20-30 psi over the maximum working pressure, and a maximum working pressure of 200 psi.

10.7.4. Refurbished Freon tanks are not acceptable.

10.7.5. Compressors are not allowed within the track.

10.7.6. Air tanks are optional.

10.7.7. Battery operated tire inflators are permitted to be used inside the pits.

10.8. MIRRORS

10.8.1. Only acceptable mirrors will be of plastic or polished metal. No glass will be permitted.



11. DRIVING PRACTICES

- 11.1. Reckless driving or unsportsmanlike conduct is grounds for penalization or immediate disqualification from the practice session or main event.
- 11.2. All competitors must always be prepared to deviate from the racing line to yield to faster drivers. Failure to do so can result in a Blue or Black flag.
- 11.3. The primary responsibility for avoiding contact with a Competitor resides with the overtaking Competitor and the secondary responsibility resides with the Competitor(s) being overtaken. A Competitor who fails to demonstrate their responsibility and initiates a maneuver that results in contact with another Competitor may be penalized.
- 11.4. All four wheels must always remain on the track except when avoiding a collision.



12. HAND SIGNALS

- 12.1. Drivers must signal by raising one hand so that karts behind them can see if they are driving out of the ordinary pattern, such as exiting to the pits, yellow flag, accidents, etc.
- 12.2. Drivers must signal by raising both hands high in the air if their kart has stalled or spun out, indicating their intention not to make any move until the field passes. Drivers in stalled or spun out karts must always get out and help push or carry the kart. Drivers should remain in their kart if it stalls on the track until track workers get the kart safely off the track. Stalled karts should cross the track only where directed by track workers. If a kart has spun out but is still running, the driver should signal the track workers with only one hand to indicate their wishes to be pushed back onto the track.
- 12.3. All hand signals should be made in such a manner so as not to confuse officials or other drivers on the track.



13. THE "HALLOWEEN HUNDRED" EXHIBITION RACE

13.1. The "Halloween Hundred" is a PGPF-run Fall exhibition race.

13.2. FORMAT

13.2.1. No more than 25 teams shall be admitted.

13.2.2. The scheduled number of laps is 100.

13.2.3. Any driver wishing to compete in the race must participate in a minimum of two practice sessions.

13.2.4. The starting lineup is determined by the fastest single lap time recorded by each kart during the practice sessions, arranged in order from fastest to slowest.

13.3. ELIGIBILITY

13.3.1. Only teams that present a kart that passed the previous year's tech inspection are eligible to register.

13.4. RULES

13.4.1. The "Halloween Hundred" shall be held in accordance with the previous year's rulebook, with the exceptions outlined in sections 13.2 and 13.3.

13.4.2. In alignment with the spirit of the Halloween Hundred as an exhibition race, all protest decisions are final.



APPENDIX A

Medical Insurance Disclaimer, Waiver, Release, and Hold Harmless Agreement

In consideration of permission granted by Purdue University allowing me to participate voluntarily in the practice sessions, qualifications, go-kart race and related activities of the 2025 Purdue Grand Prix, conducted by the Purdue Grand Prix Foundation to be held on the Purdue campus in March and April of 2025 (the "Activity"), I (together with my parent or guardian, if I am under the age of eighteen (18) or under a legal disability) represent, covenant and agree, on behalf of myself and my heirs, assigns, and any other person claiming by, under or through me, as follows:

1. I acknowledge that participating in the Activity involves certain risks (some of which I may not fully appreciate) and that property damage, significant injuries, disability, death, or other harm could occur to me or others. I accept and voluntarily incur and assume all risks of any injuries, damages, or harm that arise during or result from my participation in the Activity, including any associated travel, regardless of whether or not caused in whole or in part by the negligence or other fault of Purdue University, The Trustees of Purdue University, the Purdue Grand Prix Foundation, the Purdue Alumni Foundation, the Race Director(s), the Safety Chairman, and/or any of its or their departments, affiliates, employees, officers, agents, and insurers, together with any and all sponsors of, and all other entrants or participants in, the Grand Prix event (together, the "Released Parties").
2. I am aware that COVID-19 is an infectious virus that spreads easily through person-to-person contact, and could cause serious illness to individuals who have certain medical risk factors. Federal and state public health authorities and Released Parties have issued basic health and safety guidance aimed at mitigating the spread of the virus. I understand that my participation in Activity or accessing facilities owned or managed by Released Parties could increase the risk of contracting COVID-19. Released parties in no way warrant that the protective measures prescribed for the Activity or to access the facilities will completely prevent exposure to the COVID-19 virus. I agree to follow all public health and safety guidelines for the Activity and freely and voluntarily assume the risk of COVID-19 exposure.
3. I waive all claims against any of the Released Parties for any injuries, illness, damages, liabilities or losses, whether known or unknown, foreseen or unforeseen, which arise during or result from my participation in the Activity, regardless of whether or not caused in whole or part by the negligence or other fault of any of the Released Parties. I release and forever discharge the Released Parties from all such claims. I understand this means I give up my right to bring any such claims against the Released Parties.
4. I agree to indemnify and hold the Released Parties harmless from and against any and all losses, liabilities, damages, costs or expenses (including but not limited to reasonable attorneys' fees and other litigation costs and expenses) incurred by any of the Released Parties as a result of any claims or suits that I (or anyone claiming by, under or through me) may bring against any of the Released Parties to recover any losses, liabilities, costs, damages, or expenses that arise during or result from my participation in the Activity, regardless of whether or not caused in whole or part by the negligence or other fault of any of the Released Parties.
5. I acknowledge that I have received, understand and will abide by the 2023 Official Purdue Grand Prix Rules Packet.



APPENDIX B - VARIANCE FORM

Requestor Information

Requestor Name:

Requesting Team:

Requesting Team #:

What are you requesting a variance on?

Rule (Number and Description):

Details

Describe in detail your variance request (attach any supporting documentation):

Approval

Race Director Signature

Date & Time

Decision Rendered:



APPENDIX C - PROTEST FORM

Protestor Information

Protestor Name:

Protestor Team:

Protestor Team #:

Paid? _____

What Are You Protesting?

Scoring

Technical/Safety

Competition

Details

Describe in detail your protest:

Acknowledgement of Receipt

Protestor Signature

Date & Time

Race Director Signature

Date & Time



APPENDIX D - APPEAL FORM

Appellant Information

Appellant Name:

Appellant Team:

Appellant Team #:

Paid? _____

What Are You Appealing?

Scoring

Technical/Safety

Competition

Details

Describe in detail your appeal:

Acknowledgement of Receipt

Appellant Signature

Date & Time

Race Director Signature

Date & Time

APPENDIX E - SEAT BELT COMPONENTS

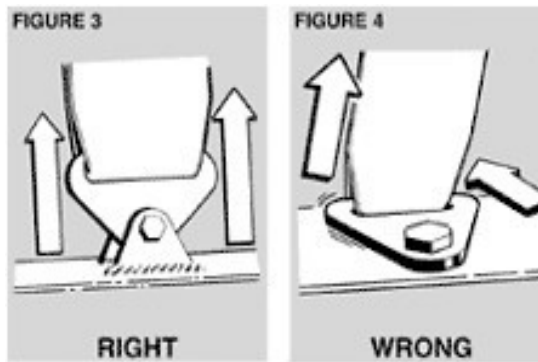
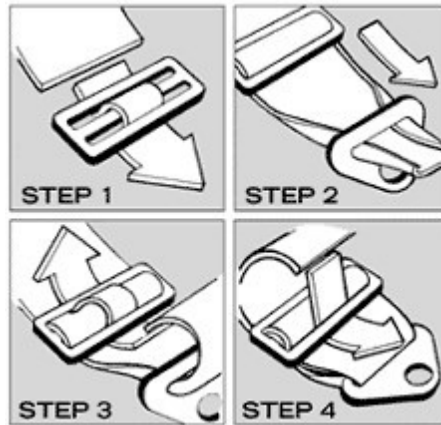
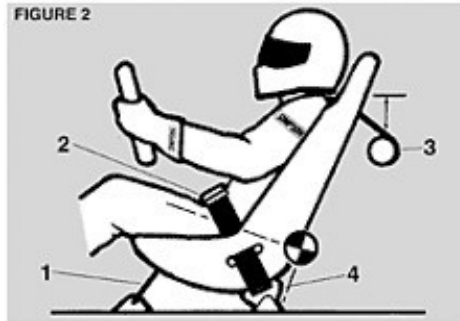

APPENDIX F - ROLL CAGE SPECIFICATIONS

Four inches of clearance between the driver's helmet and the roll cage in all directions.



Four inches of clearance between the driver's helmet and the upper most plane of the kart.



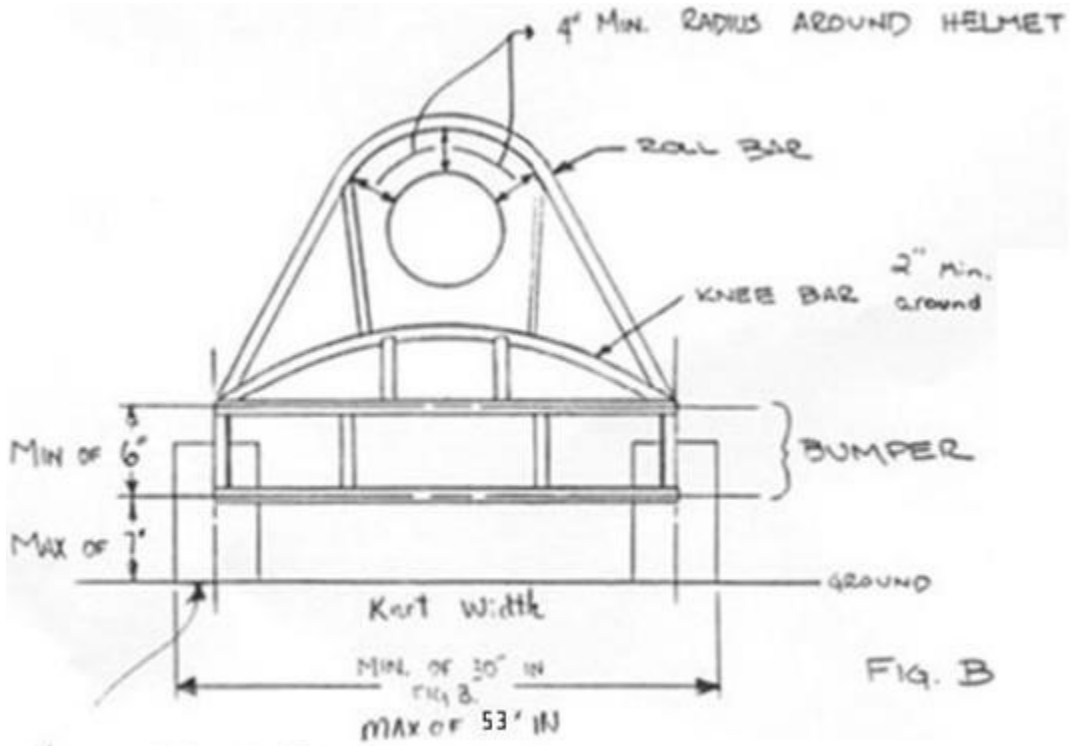

1/2 OF WHEEL MUST
AT MIN. OF 30"
TREAD WIDTH.

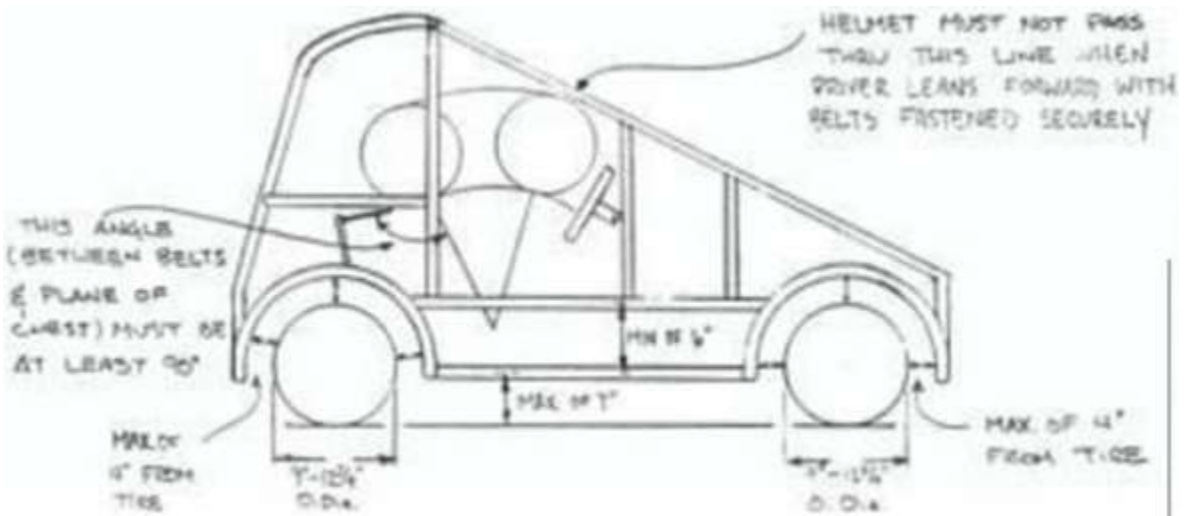

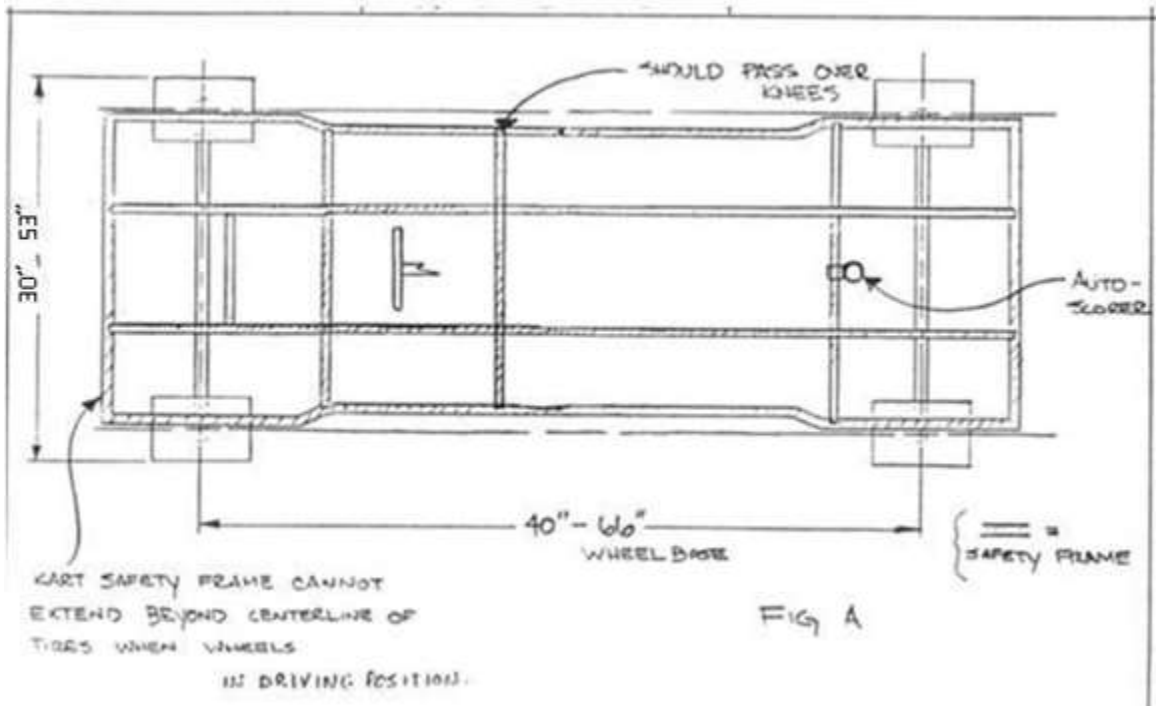

APPENDIX G - SEAT

“A” – Any part of the seat cannot be behind the axle.

“B” – These are minimum measurements.

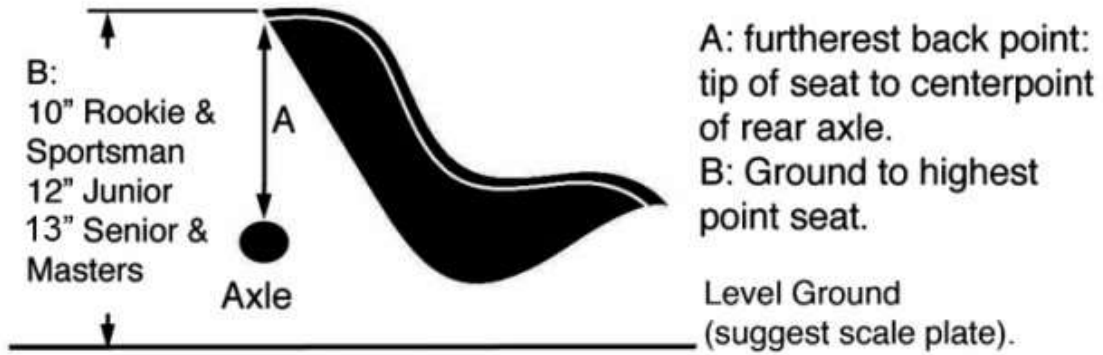

APPENDIX H - HEAD REST AND ARM RESTRAINTS



Large headrest with padding

Adjustable height to accommodate drivers of various heights

Shoulder belts supported and retained with wire to keep on shoulders



Get seated in the race car and slide the arm restraint onto the arm placing it on the forearm just below the elbow.

APPENDIX I - MOUNTING BLOCK USAGE

Acceptable Mounting Block Usage

- Bolts pass through the block, with nuts and safety wire on the back side
- Bolts completely encircle both sides of the frame
- Note: top block is cut thinner than is desirable



Not Acceptable Mounting Block Usage

- Bolts do not pass completely through the block; no nuts or wire/pins



Not Acceptable Mounting Block Usage

- Not acceptable for safety cage attachment because the clamp doesn't completely surround the frame with bolts on both sides
- Acceptable for mounting of other components provided the bolt passes through and has a nut and pin or wire (not shown).

APPENDIX J - HELMET AND RACING SUIT CERTIFICATIONS

What are the differences between the SA, M and K standards?

SA Standard was designed for auto racing while M Standard was for motorcycling and other motorsports. There are three major differences between them:

1. SA standard requires flammability test while the M standard does not.
2. SA standard allows narrower visual field than M standard (Some SA helmets may not be street legal).
3. SA standard has roll bar impact test while M standard does not.

The K standards are very similar to the SA standards; however the K standards omit the requirements for flame retardancy.



Where is the Snell label located?

There are two forms of the Snell serialized label. The most common is the adhesive label, but there is also a cloth type for the M, SA and RS standards. The adhesive label, or decal is usually affixed somewhere on the inside of the helmet. If it is not readily visible, check underneath the flaps of the comfort padding. The cloth type labels are generally sewn onto the chin strap and folded over. If a thorough search fails to turn up a decal then your helmet is not part of the Snell certification program and does not have the confidence of the Foundation.

Racing Suit Certification Labels

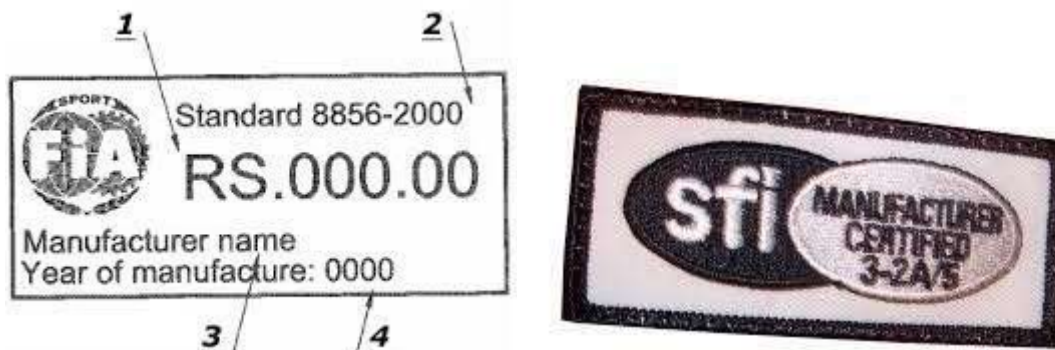



APPENDIX K - AKRA ENGINE SPECIFICATIONS

[Taken from Section 9 2017 AKRA Rules] - Two-cycle engine specific technical inspection data

Note: Generic requirements are listed in section 8.1 and are applicable in their entirety unless specifically excepted on the engine specific tech sheet. The following specifications take precedence over any contradicting requirements of section 8. Exhaust requirements per section 8.2 and class structure description. Carburetor requirements per section 8.3 and class structure description.

Engine Specific Tech Sheet for: Yamaha KT100S Description:

Two cycle, single cylinder, piston port

Displacement: 6.201 cubic inch / 101.61 cubic centimeter maximum

Combustion chamber volume: 11.00 cubic centimeter minimum

Cylinder head requirements: Matching or machining of the cylinder head or cylinder liner to accept a sealing device is prohibited. The cylinder face groove must be flat bottomed with the outside diameter of the face groove being the only method allowed for locating the cylinder head gasket. The gasket mating face of the cylinder head must be flat with no means employed to locate the cylinder head gasket. The combustion chamber must be nominally spherical in shape. Welding in the combustion chamber or spark plug area is prohibited. Cylinder head gasket shall be manufactured of aluminum or copper only, having a 2.580 inch maximum outside diameter.

Bore and stroke: 2.090 inch maximum bore, 1.816 inch maximum stroke

Intake system: Piston port

Carburetor type: Walbro WB3A only Inlet tract length: 2.600 inch minimum, 2.800 inch maximum

Intake port height dimension : .775 inch maximum

Exhaust port height dimension : 1.155 inch minimum

Port dimension diagram: T-50

Cast iron surfaces in all ports to remain as cast. Any effort to modify these surfaces by any means whatsoever is not allowed. This includes grinding, polishing, shot-peening or blasting, EDM (Electro Discharge Machining), or any other means. It is not allowed to alter ports by any means to "match" case ports, to alter by any means the shape, size, or angle of passages from the base of the cylinder to the port openings. Aluminum-only portions of the intake and exhaust tracts may be ground or polished. All surfaces in the transfer ports to remain untouched. Minor grinding nicks in the cast iron are allowed so long as they do not transit the entire width of the cast iron from the aluminum surface to the port opening. Tech inspector's discretion is allowed here. The only exception is for the grinding of one exhaust port in non-787 cylinders as outlined elsewhere in the rules. That port must be clearly marked with an "X" stamped next to the head stud above the ground port. Any effort to circumvent the intent of these rules, regardless of how accomplished, is not allowed.



Ignition system: Only stock spark plugs with a .750 inch or 20 millimeter nominal reach are allowed. Approved flywheels are Yamaha part numbers 7F6-85551-00, 7F6-85551-50 (Old style), 7F6-85551-01, 7F6-85551-51 and 7F6-85510-03-00 (New style). Flywheel outside diameter 2.350 inch minimum. New style flywheel thickness over (3) lugs .950 inch minimum, all other areas .817 inch minimum. New style lug length, (3) places .750 inch minimum. Old style flywheel thickness .827 minimum. Flywheel and crankshaft keyway width .1173 inch minimum, .1201 inch maximum. Keyway required but non tech. Ignition module must be original Yamaha, PRD or Atom, stock unaltered, silicone or epoxy damage repair is allowed. Coil may be repaired with silicone or epoxy. Alterations of any type to facilitate adjustment of flywheel or coil position to alter timing are strictly prohibited. The leading edge of the flywheel pickup magnet must line up visually with the trailing edge of the coil leg between .015 inch before top dead center to top dead center.

Piston requirements: Piston coating below the ring land only is approved. Piston skirt length must be the same within .015 inch. Maximum .030 piston skirt corner break, measured axially. Circlip circumferential height .250 inch maximum, axial width .200 inch maximum. Piston transfer areas must be as cast. Approved pistons are Yamaha, Burris (single or double ring), Wiseco, Vinart and KSI RKE-787. All approved pistons have manufacturer's name cast inside and this must be present. Piston must be domed. All pistons (except Burris double ring) must have one ring only. Rings must be manufactured of ferrous material. Wrist pin length 1.565 inch minimum. Wrist pin outside diameter .550 inch minimum, .552 inch maximum. Wrist pin inside diameter .400 inch maximum. Wrist pins must be manufactured of ferrous material. Connecting rod requirements: Approved connecting rods are Yamaha part numbers 7F6-11651-01, 7F6-11651-02 and 50W-11651-00 only. The connecting rod must be of original manufacture and stock appearing with no machining, grinding, blending or polishing allowed. Shot peening the connecting rod is allowed. Center of crankshaft journal diameter to center of wrist pin diameter 3.932 inch minimum, 3.942 inch maximum. Top or bottom connecting location is approved. If top location method is employed, the top of the rod shall have two or more spacers manufactured of steel, brass or aluminum and loose or caged bearings. The bottom of the rod shall have no spacers and a caged bearing. If bottom location method is employed, the bottom of the rod shall have a caged bearing and one spacer per side. The top of the rod shall have caged or loose bearings. If loose bearings are used at top of rod, thrust washers are allowed.

Crankshaft requirements: Original manufacture only. Crankshaft counterweights outside diameter 3.410 inch minimum, 3.435 inch maximum. Width over bearing lands 1.790 inch minimum. Inside width between counterweights .343 inch minimum. Concentric bushings may be added to repair damaged crankshaft journals. Removal of material in bearing recess area is allowed for bearing clearancing only, not for lightening or balancing purposes. Either stepped/plugged or nonstepped/non-plugged crankpins are allowed. If stepped/plugged crankpins are employed, the plugs must be in place with crankpin inside diameter of .400 inch minimum. If non-stepped/non-plugged crankpins are employed there may not be any plugs installed with crankpin inside diameter .390 inch minimum, .425 inch maximum. Additional requirements: Surface finish of aluminum portion of intake and exhaust ports are non-tech.

Crankcase pulse hole inside diameter .128 inch maximum. Pulse hole may be relocated to front of engine for use with reversed cylinder. Old style cylinders (those without cast markings) are allowed for use. The aluminum portions of the transfer passages must be as cast with the



exception of minor blending at the junction of the cast iron only. The top cast iron surface of one exhaust port may be ground to bring its dimension closer to specification. Port must be ground basically perpendicular to the bore, no freeporting. Port height dimensions apply to altered port. When altered in this fashion, an "X" must be placed above the altered port for identification



APPENDIX L - POST RACE TECHNICAL INSPECTION LIST

Purdue Grand Prix Post Race Inspection			
Date: _____			Kart #: _____
Position: _____	Team: _____	Inspector: _____	
			Initials
Total Weight	(Kart, Driver, and Gear) ≥ 360 pounds		
Rear Axle Width	≤ 5 1/8 inches		
Fuel Capacity ≤ 7 quarts	Cyclohexane		
Silencer	Induction silencer (CIK two-hole design, no additional holes except for tether)		
	Baffle tube length ≥ 3.732 inches		
	Baffle tube diameter ≤ 0.905 inches		
Exhaust Pipe	Diameter ≤ 1.750 inches		
	Silencing can diameter ≥ 3.5 inches		
	Exhaust gas outlet ≤ 0.7854 square inches (must be in rear half of can)		
Walbro WB3A Carburetor	Only stock Walbro #WB3A carburetors are allowed		
Yamaha KT100 Two-Cycle Engine	Combustion chamber volume ≥ 11 cubic centimeter		
	Cylinder bore ≤ 2.090 inches		
	Cylinder stroke ≤ 1.816 inches		
	Inlet tract length = 2.600 ~ 2.800 inches		
	Intake port height ≤ 0.775 inches		
	Exhaust port height ≥ 1.155 inches		
	Ignition module must be stock, unaltered Yamaha, PRD, or Atom		
	Piston must be Yamaha, Burris, Wiseco, Vinart, or KSI RKE-787 (domed)		
No coating above ring, single ring except Burris double ring			
Engine complies with 2017 AKRA engine specifications			
	Name	Signature	Date
Lead Technical Inspector:			
Crew Chief:			
Driver:			
Race Director:			
Race Director:			
Additional measurements may be required to determine the stock characteristics of any engine, at the discretion of the Race Director(s) and Lead Technical Inspector.			



APPENDIX M - SPRINT RACE QUALIFICATION ORDER

Position	Sprint 1	Sprint 2	Sprint 3
1	28	29	30
2	31	32	33
3	34	35	36
4	37	38	39
5	40	41	42
6	43	44	45
7	46	47	48
8	49	50	51
9	52	53	54
10	55	56	57
11	58	59	60
12	61	62	63
13	64	65	66
14	67	68	69
15	70	71	72
16	73	74	75
17	76	77	78
18	79	80	81
19	82	83	84
20	85	86	87
21	88	89	90



APPENDIX N - TRACK WORKER BEST PRACTICES - HOW TO BE A GOOD TRACK WORKER

- 1. Do not get run over!!**
 - Drivers have roll cages, helmets, and other protection; YOU DO NOT!
- 2. Stay alert and pay attention at all times!!**
 - Do not turn your back to the oncoming traffic.
 - Always look both ways before crossing the track.
 - Do not stand in the danger zones on the outsides of turns.
 - No cell phones, cameras, or other electronics allowed.
- 3. Push stalled karts off the track.**
 - Push stalled karts at least 10 feet into the grass.
 - Push karts into the infield if possible.
- 4. Push running karts onto the track.**
 - Check both ways for oncoming traffic before pushing the kart onto the track.
 - The quicker you can get a running kart moving again, the less likely it is to stall and need to be pushed back to the pits.
- 5. Do not let drivers get out while on the track.**
 - If the kart is locked up, drag it over (with the driver inside) onto the grass first. It is far too dangerous for drivers to climb out of the kart onto the track.
- 6. Put straw bales and barriers back into place after accidents.**
 - After moving the kart off the track, you can usually fix the bales while the driver is getting out.
 - Move broken bales to the back of the row.
- 7. Clear debris off the track.**
 - Small asphalt rocks are usually NOT a problem.
 - Small amounts of straw, grass, or dirt are usually NOT a problem.
 - The large rocks ARE a problem and should be swept or kicked off the track.
 - If parts come off a kart be careful picking them up because they could be very hot.
 - Show any significant parts to the nearest Race Official to address possible safety concerns.
- 8. Move with a purpose.**
 - The quicker you get the track back to racing conditions the safer it will be for the drivers.
- 9. Spread out as needed.**
 - Track workers should be evenly distributed at each corner.
 - Move to other corners as track workers leave.
- 10. Help each other out.**
 - If there is a large crash in a nearby corner, don't just stand and watch, go and help clean up.
- 11. If a kart will roll, ROLL IT, do not carry it.**
 - Drivers may complain, but we don't care. Just roll it, it's safer for everyone.
 - A broken kart is better than a broken track worker.
- 12. Cross the track at Preferred Crossing Points.**
 - See map below.
 - When crossing the track to enter pit lane, coordinate with the official at turn 5 to cross when it is safe.
- 13. Eye protection and safety vest with team number is required at all times.**
- 14. Gloves are recommended.**

Crossing Locations for Track Workers Transporting Karts to the Pits

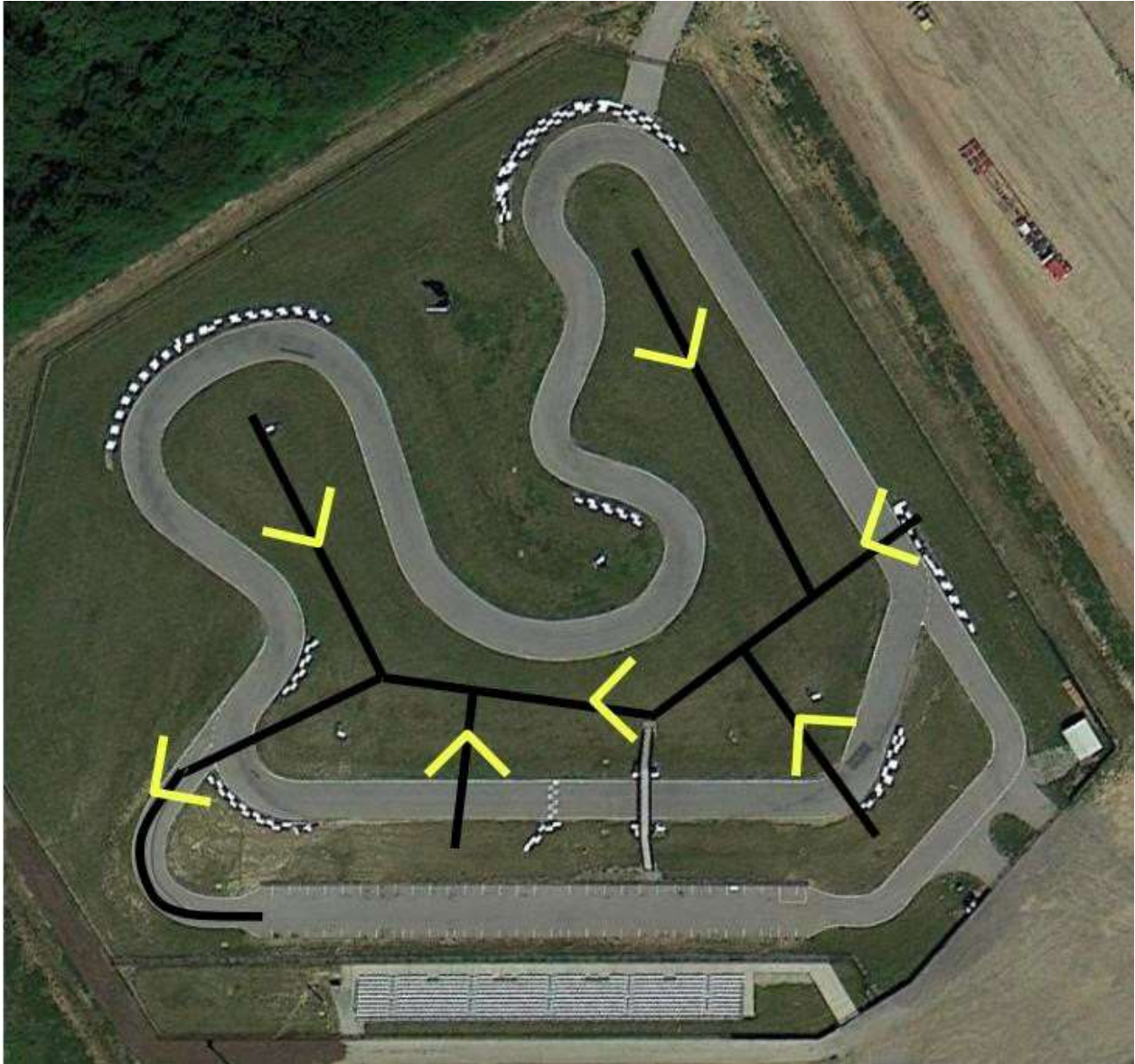

APPENDIX O - PIT SPOT ASSIGNMENTS BY QUALIFICATION ORDER

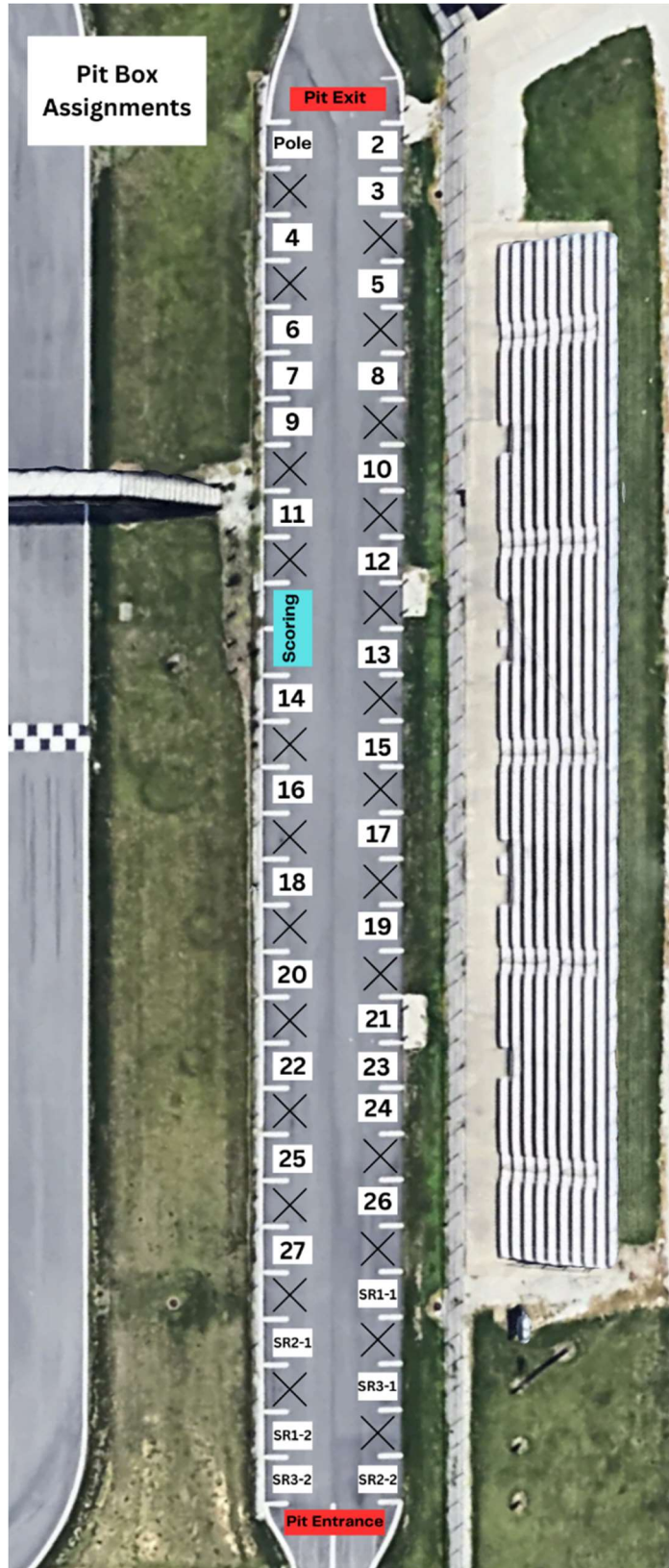

APPENDIX P - BOLT AND NUT SECUREMENT BEST PRACTICES

- Nut securement

- When safety wiring a bolt through the threads to secure a nut(s), it is best to place the safety wire as close to the tightened position of the nut(s).
- If the safety wire is placed further from the tightened position of the nut it will still secure the nut on the bolt, but the securement provided by the bolt and nut may be compromised.
- Some components on the kart may still be able to operate as normal if the nut has loosened, as long as the safety wire is securing it close to the tightened position.

- Bolt Securement

- When safety wiring a bolt, the safety wire must be secured so that the forces from the safety wire pull in the tightening direction.
- If the safety wire pulls in the loosening direction, the bolt may be loosened over time or when the safety wire is secured.
- If two or more bolts are safety wired together, the safety wire should pull in the tightening direction for all bolts.

Items shall be safety wired in such a configuration that the safety wire shall be put in tension when the parts tend to loosen.



Safety wire Bolt-Heads



Safety wire Castle Nuts



INDEX

A	
Advertisement Banner	10
Advertising	10
Air Tanks	50
Appeal Form	58
Appeals.....	29
Approval Addendum.....	78
Arm Restraints	49
At Track Procedures.....	16
B	
Batteries	42
Belts	49
Brakes.....	40
Bumpers	35
C	
Cameras	44
Castellated Nuts	42
Chain Guard.....	40
Chain Oilers	40
Clutches	40
Competition Protest	28
Composite Materials	34
Cotter Pins	42
Crew Changes.....	14
Crew Chief	13
Crew Member Clothing.....	47
Crew Size	12
D	
Driver Protective Clothing	47
Driver Restraint Systems	48
Driving Practices	51
E	
Electronic Devices	44
Eligibility	12
Engine.....	45
Entry Deadline.....	15
Entry Fees	15
Exhaust System.....	41
F	
Fire Extinguishers	48
Flags	16
Floor Pan.....	37
Frame Attachment	36
Fuel and Oil.....	45
Fuel Lines	39
Fuel Storage	46
Fuel Tank	38
Fuel Testing	46
G	
Gearboxes	40
Governing Bodies.....	5
Ground Clearance	44
H	
Hand Signals	52
Harness Support.....	37
Head Clearance.....	35, 60
Headrest	37
Helmets	47
Hold Harmless Agreement	54
I	
Impoundment.....	31
Inspection Stickers	34
K	
Kart Identification	43
Kart Specifications.....	34
Kart Width	37
Kill Switch.....	42
M	
Main Frame.....	34
Material Specification	32
Medical Insurance Form	54
Mirrors.....	33, 50
Mounting Blocks	36
N	
Neck Brace.....	47
Number Panel Requirements	43
P	
Penalties	26
Pit Passes	9
Pit Procedures	20
Pit Speed	21
Pit Stop.....	21
Plastic Items.....	33
Post Race Technical Inspection	31, 70
Practice Requirements	12



Protest Form 57
Protests 28

Q

Qualification 23

R

Race Duration 11
Rear Axle..... 41
Refunds 15
Registration Procedure 15
Releases 7
Relief Drivers..... 14
Repositioning 27
Roll Cage 34
Roll Cage Attachment..... 36
Rookie Drivers 14
Rookie Practice 14

S

Safety Belts 48
Safety Committee 6
Safety Equipment 47
Safety Frame 34
Scoring Procedures 18
Scoring Protest 28

Seat.....37
Spindle.....41
Sponsors 10
Sprint Race.....24
Stalled Karts 52, 72
Starters42
Steering.....40

T

Tank Exchange21
Technical/Safety Protest28
Throttle.....39
Tires37
Track Worker..... 13
Transponder 18

V

Variance Form56

W

Weight44
Welds41
Wheelbase 36, 37
Wheels37



APPROVAL ADDENDUM

Signature of Approval:

Grand Prix President

Grand Prix Internal Vice President

Grand Prix Race Director

Grand Prix Race Director

Grand Prix Advisor

Office of Student Activities and Organizations

Office of Risk Management